

HWF 2512-5612

Heat pump reversible on the water side

Cooling capacity 629,5 ÷ 1438,2 kW
 Heating capacity 697,7 ÷ 1576,8 kW

- Optimised for high condenser temperatures for example units operating in heating mode
- Maximum condenser leaving water temperature: 60°C
- Electronic thermostatic as standard



DESCRIPTION

Units for internal installation offering chilled/hot water, designed to meet air conditioning needs in residential/commercial complexes or industrial applications.

Compact and flexible, perfect alignment to the requested load thanks to an accurate control algorithm.

The base, the structure and the panels are made of galvanized steel treated with polyester paint RAL 9003.

VERSIONS

° Standard

A High efficiency

FEATURES

Operating field

Production of chilled water up to -8°C of water produced on the evaporator side, but also suitable for use in heat pump mode with condenser water temperature up to 60°C.

Dual-circuit unit

Unit with 2 refrigerant circuits designed to provide maximum efficiency at full load, ensuring high efficiency at partial loads also and ensuring continuity in case one of the circuits stops.

They are equipped with screw compressors and system and source side shell and tube heat exchangers with R134a refrigerant.

Electronic expansion valve

The possibility to use electronic expansion valve, offers significant benefits, especially when the chiller is working with partial loads, increasing the energy efficiency of the unit. Standard for all sizes.

CONTROL

pCO³ control type

Microprocessor adjustment, with keyboard and LCD display, for easy access on the unit is a menu available in several languages.

Adjustment includes complete management of the alarms and their log.

Possibility to control two units in a Master-Slave configuration

The presence of a programmable timer allows functioning time periods and a possible second set-point to be set.

The temperature control takes place with the integral proportional logic, based on the water output temperature.

ACCESSORIES

AER485P1 x n° 2: RS-485 interface for supervision systems with MODBUS protocol.

AERNET: The device allows the control, the management and the remote monitoring of a Chiller with a PC, smartphone or tablet using Cloud connection. AERNET works as Master while every unit connected is configured as Slave (max. 6 unit); also, with a simple click is possible to save a log file with all the connected unit datas in the personal terminal for post analysis.

MULTICHILLER_EVO: Control, switch-on and switch-off system of the single chillers where multiple units are installed in parallel, always ensuring constant flow rate to the evaporators.

PRV3: Allows you to control the chiller at a distance.

AVX: Spring anti-vibration supports.

FACTORY FITTED ACCESSORIES

RIF: Power factor correction. Connected in parallel to the motor allowing about 10% reduction of input current.

IS: Condenser isolating valves. Mandatory accessory for units operating in heat pump mode. Factory fitted only.

AKW: Acoustic kit that lowers the noise level even further, thanks to the special coating on the panelling or on those components that produce the most noise in the unit. Available for the low noise version only.

ACCESSORIES COMPATIBILITY

| Model | Ver | 2512 | 2812 | 3212 | 3612 | 4212 | 4812 | 5612 |
|---------------------|-----|------|------|------|------|------|------|------|
| AER485P1 x n° 2 (1) | °A | . | . | . | . | . | . | . |
| AERNET | °A | . | . | . | . | . | . | . |
| MULTICHILLER_EVO | °A | . | . | . | . | . | . | . |
| PRV3 | °A | . | . | . | . | . | . | . |

(1) x Indicates the quantity of accessories to match.

Antivibration

| Ver | 2512 | 2812 | 3212 | 3612 | 4212 | 4812 | 5612 |
|------------------|--------|--------|--------|--------|--------|--------|--------|
| Set-up: ° | | | | | | | |
| ° | AVX673 | AVX673 | AVX673 | AVX674 | AVX674 | AVX674 | AVX675 |
| A | AVX673 | AVX673 | AVX674 | AVX675 | AVX675 | AVX675 | AVX676 |
| Set-up: L | | | | | | | |
| ° | AVX673 | AVX673 | AVX674 | AVX674 | AVX674 | AVX674 | AVX675 |
| A | AVX674 | AVX674 | AVX675 | AVX675 | AVX675 | AVX675 | AVX676 |

RIF: Power factor correction

| Ver | 2512 | 2812 | 3212 | 3612 | 4212 | 4812 | 5612 |
|-----|------------|------------|------------|------------|------------|------------|------------|
| °A | RIFHWF2512 | RIFHWF2812 | RIFHWF3212 | RIFHWF3612 | RIFHWF4212 | RIFHWF4812 | RIFHWF5612 |

A grey background indicates the accessory must be assembled in the factory

For the size of the units with the RIF accessory we ask you to contact the headquarters.

IS: isolating kit

| Ver | 2512 | 2812 | 3212 | 3612 | 4212 | 4812 | 5612 |
|-----|---------|---------|---------|---------|---------|---------|---------|
| ° | IS1 (1) | IS1 (1) | IS1 (1) | IS1 (1) | IS1 (1) | IS1 (1) | IS2 (1) |
| A | IS1 (1) | IS1 (1) | IS2 (1) | IS2 (1) | IS2 (1) | IS2 (1) | IS3 (1) |

(1) Mandatory accessory for heating mode operation

A grey background indicates the accessory must be assembled in the factory

Acoustic kit

| Ver | 2512 | 2812 | 3212 | 3612 | 4212 | 4812 | 5612 |
|------------------|---------|---------|---------|---------|---------|---------|---------|
| Set-up: L | | | | | | | |
| °A | AKW (1) | AKW (1) | AKW (1) | AKW (1) | AKW (1) | AKW (1) | AKW (1) |

(1) Available only in low noise version

A grey background indicates the accessory must be assembled in the factory

CONFIGURATOR

| Field | Description |
|----------------|---|
| 1,2,3 | HWF |
| 4,5,6,7 | Size 2512, 2812, 3212, 3612, 4212, 4812, 5612 |
| 8 | Model |
| ° | Optimised for high condenser temperatures |
| 9 | Version |
| ° | Standard |
| A | High efficiency |
| 10 | Set-up |
| ° | Standard |
| L | Silenced |
| 11 | Heat recovery |
| ° | Without heat recovery |
| D | With desuperheater |
| T | With total recovery (1) |
| 12 | Evaporator |
| ° | Standard |
| E | Evaporating unit |
| 13 | Power supply |
| ° | 400V ~ 3 50Hz with fuses |
| 5 | 500V ~ 3 50Hz with fuses (2) |
| 8 | 400V ~ 3 50Hz with magnet circuit breakers |
| 9 | 500V ~ 3 50Hz with magnet circuit breakers (3) |

(1) Not available for the condenserless (E)

(2) 500V ~ 3 50Hz with fuses only for size 2512 - 2812

(3) 500V ~ 3 50Hz with magnet circuit breakers only for size 2512 - 2812

PERFORMANCE SPECIFICATIONS

HWF - °

| Size | | 2512 | 2812 | 3212 | 3612 | 4212 | 4812 | 5612 |
|--|-----|--------|--------|--------|--------|--------|--------|--------|
| Cooling performance 12 °C / 7 °C (1) | | | | | | | | |
| Cooling capacity | kW | 630,0 | 716,0 | 846,0 | 949,0 | 1095,0 | 1261,0 | 1421,0 |
| Input power | kW | 127,0 | 144,0 | 169,0 | 191,0 | 220,0 | 252,0 | 286,0 |
| Cooling total input current | A | 226,0 | 255,0 | 286,0 | 314,0 | 378,0 | 426,0 | 488,0 |
| EER | W/W | 4,96 | 4,97 | 5,01 | 4,97 | 4,98 | 5,00 | 4,97 |
| Water flow rate system side | l/h | 108241 | 123017 | 145352 | 163049 | 188133 | 216654 | 244144 |
| Pressure drop system side | kPa | 41,0 | 56,0 | 53,0 | 44,0 | 41,0 | 60,0 | 65,0 |
| Water flow rate source side | l/h | 129991 | 147681 | 174306 | 195762 | 225816 | 259827 | 293127 |
| Pressure drop source side | kPa | 16 | 16 | 17 | 15 | 17 | 23 | 18 |
| Heating performance 40 °C / 45 °C (2) | | | | | | | | |
| Heating capacity | kW | 697,4 | 792,2 | 934,8 | 1050,2 | 1211,3 | 1393,4 | 1572,5 |
| Input power | kW | 151,1 | 171,3 | 201,0 | 227,2 | 261,7 | 299,8 | 340,2 |
| Heating total input current | A | 269,0 | 303,0 | 340,0 | 374,0 | 450,0 | 507,0 | 580,0 |
| COP | W/W | 4,62 | 4,62 | 4,65 | 4,62 | 4,63 | 4,65 | 4,62 |
| Water flow rate system side | l/h | 121208 | 137688 | 162463 | 182522 | 210527 | 242177 | 273304 |
| Pressure drop system side | kPa | 14,0 | 14,0 | 15,0 | 13,0 | 15,0 | 20,0 | 16,0 |
| Water flow rate source side | l/h | 158554 | 180198 | 212916 | 238838 | 275582 | 317360 | 357628 |
| Pressure drop source side | kPa | 88 | 120 | 114 | 94 | 88 | 129 | 139 |

(1) Date 14511:2018; Water user side 12 °C / 7 °C; Water source side 30 °C / 35 °C

(2) Date 14511:2018; Water user side 40 °C / 45 °C; Water source side 10 °C / 7 °C

HWF - A

| Size | | 2512 | 2812 | 3212 | 3612 | 4212 | 4812 | 5612 |
|--|-----|--------|--------|--------|--------|--------|--------|--------|
| Cooling performance 12 °C / 7 °C (1) | | | | | | | | |
| Cooling capacity | kW | 645,0 | 733,0 | 858,0 | 969,0 | 1112,0 | 1253,0 | 1439,0 |
| Input power | kW | 123,0 | 140,0 | 164,0 | 185,0 | 212,0 | 239,0 | 275,0 |
| Cooling total input current | A | 221,0 | 249,0 | 278,0 | 306,0 | 367,0 | 408,0 | 471,0 |
| EER | W/W | 5,24 | 5,24 | 5,23 | 5,24 | 5,25 | 5,24 | 5,23 |
| Water flow rate system side | l/h | 110818 | 125938 | 147414 | 166485 | 191054 | 215280 | 247237 |
| Pressure drop system side | kPa | 44,0 | 60,0 | 57,0 | 41,0 | 59,0 | 40,0 | 42,0 |
| Water flow rate source side | l/h | 131931 | 149967 | 175561 | 198238 | 227443 | 256303 | 294435 |
| Pressure drop source side | kPa | 65 | 66 | 68 | 66 | 67 | 72 | 77 |
| Heating performance 40 °C / 45 °C (2) | | | | | | | | |
| Heating capacity | kW | 706,1 | 802,7 | 939,7 | 1061,0 | 1217,2 | 1371,7 | 1575,9 |
| Input power | kW | 146,3 | 166,5 | 195,1 | 220,1 | 252,2 | 284,3 | 327,1 |
| Heating total input current | A | 263,0 | 296,0 | 331,0 | 364,0 | 437,0 | 485,0 | 560,0 |
| COP | W/W | 4,83 | 4,82 | 4,82 | 4,82 | 4,83 | 4,82 | 4,82 |
| Water flow rate system side | l/h | 122715 | 139500 | 163314 | 184400 | 211554 | 238401 | 273893 |
| Pressure drop system side | kPa | 56,0 | 57,0 | 59,0 | 57,0 | 58,0 | 62,0 | 67,0 |
| Water flow rate source side | l/h | 162329 | 184476 | 215935 | 243871 | 279861 | 315346 | 362158 |
| Pressure drop source side | kPa | 94 | 129 | 122 | 88 | 127 | 86 | 90 |

(1) Date 14511:2018; Water user side 12 °C / 7 °C; Water source side 30 °C / 35 °C

(2) Date 14511:2018; Water user side 40 °C / 45 °C; Water source side 10 °C / 7 °C

ENERGY DATA

| Size | | 2512 | 2812 | 3212 | 3612 | 4212 | 4812 | 5612 | |
|---|---|------|--------|--------|--------|--------|--------|--------|--------|
| Cooling capacity with low leaving water temp (UE n° 2016/2281) | | | | | | | | | |
| SEER | ° | W/W | 5,76 | 5,77 | 5,80 | 5,82 | 5,78 | 5,82 | 5,84 |
| | A | W/W | 5,87 | 5,84 | 5,87 | 5,92 | 5,88 | 5,94 | 5,97 |
| ηsc | ° | % | 227,30 | 227,80 | 228,90 | 229,70 | 228,20 | 229,70 | 230,40 |
| | A | % | 231,60 | 230,70 | 231,90 | 233,80 | 232,20 | 234,40 | 235,70 |

ELECTRIC DATA

| Size | | 2512 | 2812 | 3212 | 3612 | 4212 | 4812 | 5612 |
|-----------------------|---|-------|-------|-------|-------|-------|-------|--------|
| Electric data | | | | | | | | |
| Maximum current (FLA) | A | 370,0 | 418,0 | 468,0 | 516,0 | 612,0 | 690,0 | 776,0 |
| Peak current (LRA) | A | 545,0 | 613,0 | 670,0 | 723,0 | 892,0 | 995,0 | 1193,0 |

GENERAL TECHNICAL DATA

| Size | | | 2512 | 2812 | 3212 | 3612 | 4212 | 4812 | 5612 |
|--|----|-------|------|------|------|----------------|------|------|------|
| Compressor | | | | | | | | | |
| Type | °A | type | | | | Screw | | | |
| Compressor regulation | °A | Type | | | | On-Off | | | |
| Number | °A | no. | 2 | 2 | 2 | 2 | 2 | 2 | 2 |
| Circuits | °A | no. | 2 | 2 | 2 | 2 | 2 | 2 | 2 |
| Refrigerant | °A | type | | | | R134a | | | |
| System side heat exchanger | | | | | | | | | |
| Type | °A | type | | | | Shell and tube | | | |
| Number | °A | no. | 1 | 1 | 1 | 1 | 1 | 1 | 1 |
| Source side heat exchanger | | | | | | | | | |
| Type | °A | type | | | | Shell and tube | | | |
| Number | °A | no. | 2 | 2 | 2 | 2 | 2 | 2 | 2 |
| System side hydraulic connections | | | | | | | | | |
| Connections (in/out) | °A | Type | | | | Grooved joints | | | |
| Sizes (in/out) | ° | ∅ | 6" | 6" | 6" | 8" | 8" | 8" | 8" |
| | A | ∅ | 8" | 8" | 8" | 10" | 10" | 10" | 10" |
| Source side hydraulic connections | | | | | | | | | |
| Connections (in/out) | °A | Type | | | | Grooved joints | | | |
| Sizes (in/out) | ° | ∅ | 5" | 5" | 5" | 5" | 5" | 5" | 6" |
| | A | ∅ | 4" | 4" | 5" | 5" | 5" | 5" | 6" |
| Size | | | 2512 | 2812 | 3212 | 3612 | 4212 | 4812 | 5612 |
| Set-up: ° | | | | | | | | | |
| Sound data | | | | | | | | | |
| Sound power level | °A | dB(A) | 97,3 | 95,5 | 94,6 | 93,7 | 93,5 | 94,0 | 93,6 |
| Sound pressure level (10 m) | ° | dB(A) | 65,1 | 63,4 | 62,5 | 61,6 | 61,4 | 62,0 | 61,6 |
| | A | dB(A) | 65,0 | 63,3 | 62,4 | 61,5 | 61,3 | 61,9 | 61,5 |
| Set-up: L | | | | | | | | | |
| Sound data | | | | | | | | | |
| Sound power level | °A | dB(A) | 85,5 | 86,2 | 87,0 | 87,9 | 90,2 | 89,8 | 91,0 |
| Sound pressure level (10 m) | ° | dB(A) | 53,5 | 54,2 | 54,9 | 55,8 | 58,1 | 57,7 | 58,8 |
| | A | dB(A) | 53,4 | 54,1 | 54,8 | 55,7 | 58,0 | 57,6 | 58,7 |

DIMENSIONS

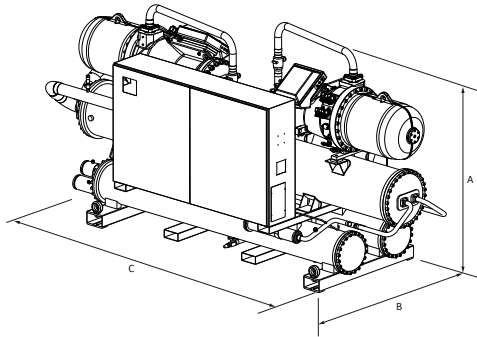

| Size | | | 2512 | 2812 | 3212 | 3612 | 4212 | 4812 | 5612 |
|-------------------------------|---|----|------|------|------|------|------|------|------|
| Dimensions and weights | | | | | | | | | |
| A | ° | mm | 2100 | 2100 | 2050 | 2120 | 2140 | 2140 | 2210 |
| | A | mm | 2180 | 2180 | 2190 | 2340 | 2340 | 2340 | 2380 |
| B | ° | mm | 1470 | 1470 | 1470 | 1520 | 1550 | 1550 | 1600 |
| | A | mm | 1470 | 1470 | 1537 | 1695 | 1695 | 1695 | 1700 |
| C | ° | mm | 3690 | 3690 | 4030 | 4030 | 4370 | 4370 | 4610 |
| | A | mm | 4330 | 4330 | 4330 | 4370 | 4550 | 4550 | 4800 |
| Empty weight | ° | kg | 3570 | 3650 | 4470 | 4750 | 5050 | 5180 | 6030 |
| | A | kg | 4080 | 4140 | 5470 | 5950 | 6240 | 6440 | 7230 |

Aermec si riserva la facoltà di apportare in qualsiasi momento tutte le modifiche ritenute necessarie per il miglioramento del prodotto con eventuale modifica dei relativi dati tecnici.

Aermec S.p.A.
Via Roma, 996 - 37040 Bevilacqua (VR) - Italia
Tel. 0442633111 - Telefax 044293577
www.aermec.com

Numero Verde
800-843085