

HMG

Reversible air/water heat pump

Cooling capacity 32 ÷ 60 kW
Heating capacity 35 ÷ 65 kW



- New R32 ecological refrigerant gas
- Touch-screen control panel
- Easy and quick to install
- Reliability and compactness
- Modularity



DESCRIPTION

HMG the new outdoor reversible inverter heat pump system for producing chilled and heated water. These units are designed to meet the plant engineering needs of residential or commercial contexts, or industrial applications. HMG formed of fully independent modules that can be linked together to create a modular system, with the possibility to connect units of different power levels. The base, the structure and the panels are made of galvanized steel treated with polyester paint.

FEATURES

Operating limits

Operation from -20°C outside air temperature (winter) to 52°C (summer).
Production of hot water up to 50 °C.

For more information about the operating limits of these units, refer to the specific paragraph on this product data sheet.

Modularity

HMG an outdoor modular system of reversible inverter heat pumps for producing hot and chilled water, with connectable base modules purposely designed to minimise the overall dimensions. Units of different power levels can be connected.

Modularity allows the installation of these units to be adapted to the real system development requirements, so the installed power can be increased over time in a simple and cost effective manner.

On the basis of these requirements, the user can choose either: **homogeneous modularity** or **sequential modularity**.

Homogeneous modularity

Made possible with the use of a control panel **TCP** (mandatory accessory) to be connected to the master unit of the system.

This type of modularity allows the modules to work with a homogeneous capacity control logic whilst still guaranteeing delay switch-on and switch-off to avoid power consumption peaks and intelligent defrosting (the simultaneous defrosting of up to 1/3 of the modules installed).

Up to 16 modules can be linked together with this operating mode.

To take full advantage of the characteristics of this working mode, you are advised to use it in systems with a pump (or a group of pumps) that serves all the units. The control logic manages the switch-on and switch-off of the pump(s) on the basis of the operating conditions of the generation system.

Sequential modularity

Made possible with the use of accessories **TCP**, **IC-2P**, **VMF-485LINK** and **VMF-E6**.

This type of modularity allows the HMG units to be added to the control system of the whole hydraulic/aeraulic system, so DHW can also be managed.

Unit switch-on and switch-off is managed in a sequential manner, according to a selected control logic (free regulation, regulation by load or regulation by temperature difference).

For more information about VMF system, refer to the dedicated documentation.

Up to 4 modules can be linked together with this operating mode HMG. Management is optimised for systems where each unit commands its own pump.

Main components

- Flow switch.
- DC brushless axial flow fans designed for aerodynamic optimisation, reducing the noise level whilst at the same time increasing the efficiency and air flow rate.
- Compressor twin rotary inverter.
- Special coil with fin golden coating.
- High-efficiency shell & tube heat exchanger (system side) for excellent reliability and a long lifespan.
- Electronic expansion valve.
- Fitted with a electrical anti-freeze heater (in unit base) to avoid the formation of ice and encourage the drainage of condensate during heating operation.

Regulation

Adjustment via **touch-screen control panel (TCP accessory compulsory)**:

- management of (up to) two pumps (not supplied) that can work alternately, boosting the reliability of the system,
- management of (up to) two auxiliary electric resistors (not supplied),
- **Quiet** function for reduced noise operation,
- climatic regulation function,
- unit anti-freeze protection at low temperatures,
- weekly programming in time periods,
- high and low pressure protection,
- smart compressor control, extending the lifespan of the unit and enhancing its reliability,
- alarm history.

Special golden fin coil

Unlike normal batteries, this special golden epoxy coating silicon free is able to protect the heat exchanger against rust and corrosion, in areas where the air has a high salt content.

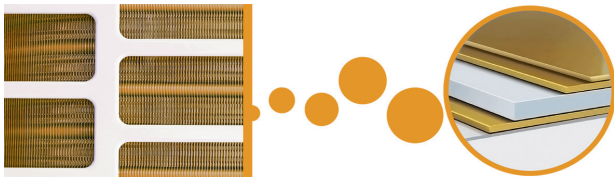

ACCESSORIES

TCP: Touch-screen control panel. (Accessory compulsory).

IC-2P: Connector for communication via Mod Bus or VMF-485LINK. Accessory compulsory if combined with VMF-485LINK, or for third party supervision systems.

VMF-485LINK: Expansion to interface the unit with the VMF communication protocol, making it possible to manage it from the VMF-E5 or VMF-E6 supervisors.

VMF-E6: White flush-mounting panel with 4.3 inch colour touchscreen. For the centralised command/control of a complete hydronic/aerualic system consisting of: fan coils (up to 64 fan coil zones formed of 1 master + max. 5 slaves), heat pumps (up to 4), MZC accessories (up to 5) for the management of radiant panels (using a suitable number of VMF-REB accessories, up to 64 radiant panels associated with the fan coil zones and up to 32 radiant panels associated with the zones served by MZC), the complete management of DHW production, control of the RAS heater and/or the boiler, management of digital I/Os, control of heat recovery units and VOC probes (up to 4).

COMPATIBILITY WITH VMF SYSTEM

For more information about VMF system, refer to the dedicated documentation.

OPERATING LIMITS

Cooling mode

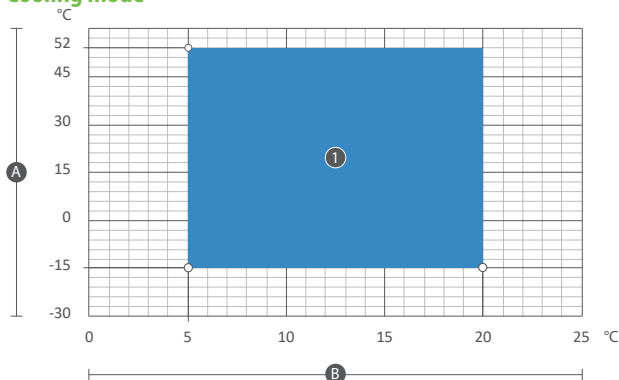

KEY

- 1 cooling mode
- A outdoor air temperature (°C)
- B water produced temperature (°C)

Heating mode range

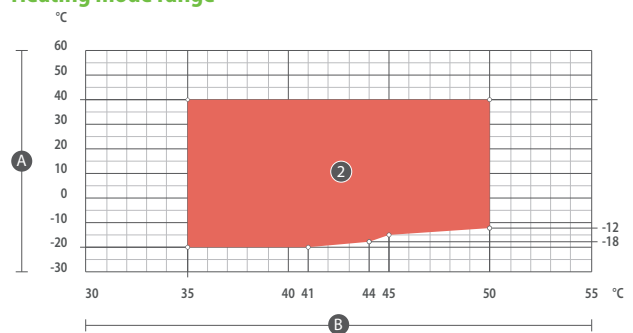

KEY

- 2 heating mode
- A outdoor air temperature (°C)
- B water produced temperature (°C)

MODULARITY

Homogeneous modularity - connection diagram

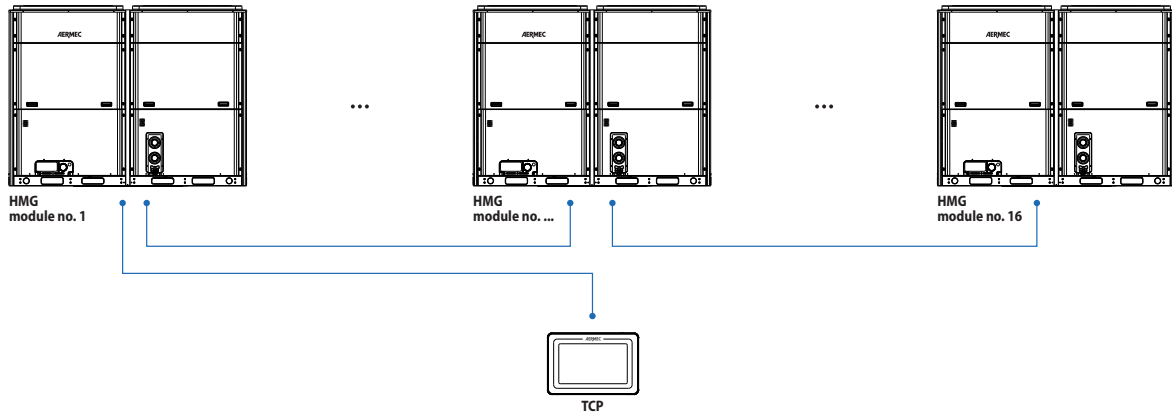

Sequential modularity - connection diagram

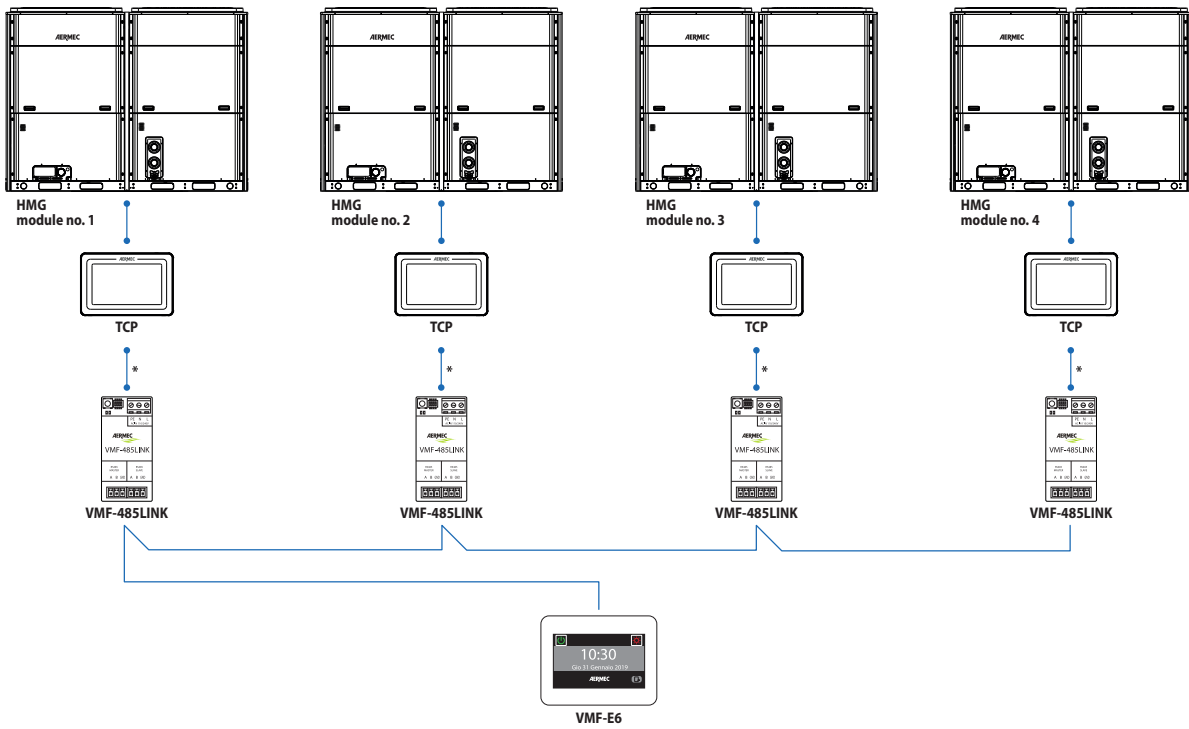

* Connection to be made with the aid of the accessory IC-2P.

PERFORMANCE SPECIFICATIONS

		HMG0350	HMG0600
Cooling performance 12 °C / 7 °C (1)			
Cooling capacity	kW	32,0	60,0
Input power	kW	11,7	20,8
Water flow rate system side	l/h	5528	10346
Pressure drop system side	kPa	80	55
Cooling total input current	A	19,2	32,9
EER	W/W	2,74	2,88
Heating performance 40 °C / 45 °C (2)			
Heating capacity	kW	35,0	65,0
Input power	kW	10,6	19,9
Water flow rate system side	l/h	6039	11249
Heating total input current	A	17,5	30,7
COP	W/W	3,30	3,27
Cooling performance 23 °C / 18 °C (3)			
Cooling capacity	kW	41,4	72,5
Input power	kW	10,5	19,1
Water flow rate system side	l/h	7198	12574
Cooling total input current	A	16,2	31,0
EER	W/W	3,94	3,80
Heating performance 30 °C / 35 °C (4)			
Heating capacity	kW	36,0	62,6
Input power	kW	8,8	15,1
Water flow rate system side	l/h	6191	10798
Heating total input current	A	12,4	24,2
COP	W/W	4,09	4,15

(1) Data EN 14511:2022; Heat exchanger water (services side) 12°C / 7°C; outside air 35°C

(2) Data EN 14511:2022; System side water heat exchanger 40 °C / 45 °C; Outside air 7 °C d.b. / 6 °C w.b.

(3) Data EN 14511:2022; System side water heat exchanger 23 °C / 18 °C; External air 35 °C

(4) Data EN 14511:2022; System side water heat exchanger 30 °C / 35 °C; External air 7 °C d.b. / 6 °C w.b.

ENERGY DATA

		HMG0350	HMG0600
UE 811/2013 performance in average ambient conditions (average) - 35 °C - Pdesignh ≤ 70 kW (1)			
Pdesignh	kW	24	51
SCOP	W/W	3,90	3,90
ηsh	%	153,00	153,00
Efficiency energy class		A++	A++
Cooling capacity with low leaving water temp (UE n° 2016/2281)			
ηsc	%	173,00	181,00
SEER	W/W	4,40	4,60

(1) Efficiencies for low temperature applications (35 °C)

ELECTRIC DATA

		HMG0350	HMG0600
Electric data			
Rated current input (1)	A	22,0	52,0
Power supply			
Power supply		380-415V 3N ~ 50Hz	380-415V 3N ~ 50Hz

(1) The rated power input (rated current input) is the maximum input electrical power (maximum current input) from the system, in accordance with the Standards EN 60335-1 and EN 60335-2-40.

GENERAL TECHNICAL DATA

		HMG0350	HMG0600
Compressor			
Type	type	Inverter rotary	
Number	no.	1	2
Circuits	no.	1	2
Refrigerant	type	R32	
Refrigerant load circuit 1 (1)	kg	5,5	5,5
Refrigerant load circuit 2 (1)	kg	0,0	5,5
System side heat exchanger			
Type	type	Shell and tube	
Number	no.	1	1
Connections (in/out)	Type	G1" 1/2 (male)	G2" (male)
Fan			
Type	type	Axial	
Fan motor	type	Inverter	
Number	no.	2	2
Air flow rate	m ³ /h	12600	24000
Sound data calculated in cooling mode (2)			
Sound power level	dB(A)	81,0	86,0
Sound pressure level (10 m)	dB(A)	49,5	54,3
Sound pressure level (1 m)	dB(A)	65,0	69,0

(1) The load indicated in the table is an estimated and preliminary value. The final value of the refrigerant load is indicated on the unit's technical label. For further information contact the office.

(2) Sound power calculated on the basis of measurements made in accordance with UNI EN ISO 9614-2, as required for Eurovent certification. Sound pressure (cold functioning) measured in free field, 10m away from the unit external surface (in compliance with UNI EN ISO 3744).

DIMENSIONS

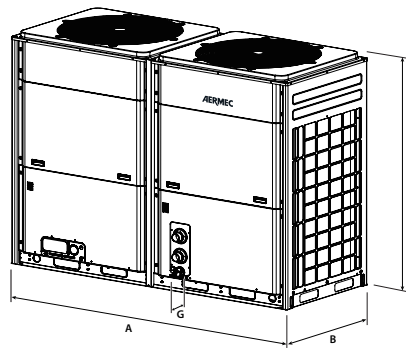

		HMG0350	HMG0600
Dimensions and weights			
A	mm	1340	2200
B	mm	765	880
C	mm	1605	1675
G	mm	80	85
D	mm	1420	2267
E	mm	920	1030
F	mm	1775	1867
Net weight	kg	405,0	686,0
Weight for transport	kg	422,0	722,0

G: tap protrusion

Aermec reserves the right to make any modifications deemed necessary. All data is subject to change without notice. Aermec does not assume responsibility or liability for errors or omissions.

Aermec S.p.A.
Via Roma, 996 - 37040 Bevilacqua (VR) - Italia
Tel. 0442633111 - Telefax 044293577
www.aermec.com