

HWS 0601 - 2802

Water cooled heat pump reversible water side

Cooling capacity 146,7 ÷ 714,3 kW
 Heating capacity 163,9 ÷ 799,6 kW



- High efficiency all in Class A Eurovent
- Unit optimised for high condenser temperatures.
- Optimised for geothermal applications
- Available also R513A (XP10) refrigerant gas

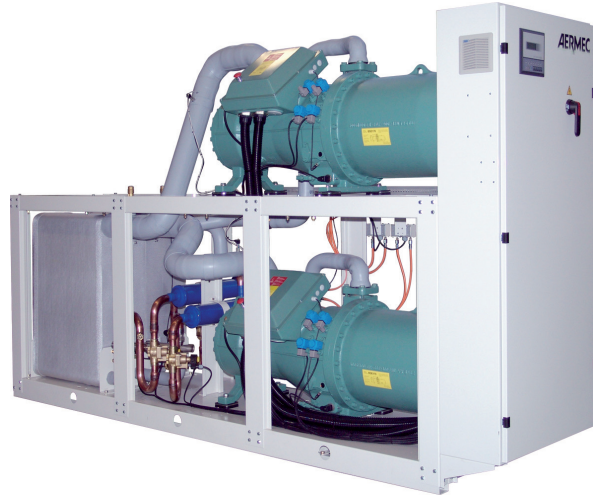

DESCRIPTION

Units for internal installation offering chilled/hot water, designed to meet air conditioning needs in residential/commercial complexes or industrial applications.

Compact and flexible, perfect alignment to the requested load thanks to an accurate control algorithm.

The base, the structure and the panels are made of galvanized steel treated with polyester paint RAL 9003.

VERSIONS

- ° Standard
- L Standard silenced

FEATURES

Operating field

Full-load operation with the production of chilled water 4-16 °C, and the possibility to produce also hot water for the condenser up to 60 °C. (for more information, refer to the technical documentation).

Units mono or dual-circuit

Depending on the size, the units are one-circuit or two-circuit models to ensure maximum efficiency with full loads as well as partial loads and guarantee operation continuity if one of the circuits stop.

They are equipped with screw compressors and system and source side plate heat exchangers.

Electronic expansion valve

The possibility to use electronic expansion valve, offers significant benefits, especially when the chiller is working with partial loads, increasing the energy efficiency of the unit. Standard for all sizes.

Integral acoustic enclosure

For all versions, if required, it is available the integral acoustic enclosure, which can further reduce the sound level.

CONTROL PC0₅

Microprocessor adjustment, with keyboard and LCD display, for easy access on the unit is a menu available in several languages.

Adjustment includes complete management of the alarms and their log.

Possibility to control two units in a Master-Slave configuration

The presence of a programmable timer allows functioning time periods and a possible second set-point to be set.

The temperature control takes place with the integral proportional logic, based on the water output temperature.

ACCESSORIES

AER485P1: RS-485 interface for supervision systems with MODBUS protocol.

AER485P1 x n° 2: RS-485 interface for supervision systems with MODBUS protocol.

AERBACP: Ethernet communication Interface for protocols Bacnet/IP, Modbus TCP/IP, SNMP

AERNET: The device allows the control, the management and the remote monitoring of a Chiller with a PC, smartphone or tablet using Cloud connection. AERNET works as Master while every unit connected is configured as Slave (max. 6 unit); also, with a simple click is possible to save a log file with all the connected unit datas in the personal terminal for post analysis.

MULTICHILLER_EVO: Control, switch-on and switch-off system of the single chillers where multiple units are installed in parallel, always ensuring constant flow rate to the evaporators.

PRV3: Allows you to control the chiller at a distance.

AVX: Spring anti-vibration supports.

FACTORY FITTED ACCESSORIES

RIF: Power factor correction. Connected in parallel to the motor allowing about 10% reduction of input current.

AKW: Acoustic kit that lowers the noise level even further, thanks to the special coating on the panelling or on those components that produce the most noise in the unit. Available for the low noise version only.

ACCESSORIES COMPATIBILITY

Model	Ver	0601	0701	0801	0901	1101	1202	1402	1602	1802	2002	2202	2502	2802
AER485P1	°L	*	*	*	*	*								
AER485P1 x n° 2 (1)	°L						*	*	*	*	*	*	*	*
AERBACP	°L	*	*	*	*	*	*	*	*	*	*	*	*	*
AERNET	°L	*	*	*	*	*	*	*	*	*	*	*	*	*
MULTICHILLER_EVO	°L	*	*	*	*	*	*	*	*	*	*	*	*	*
PRV3	°L	*	*	*	*	*	*	*	*	*	*	*	*	*

(1) x Indicates the quantity of accessories to match.

Antivibration

Version	Heat recovery	Evaporator	0601	0701	0801	0901	1101	1202	1402
°	°	°	AVX651	AVX651	AVX652	AVX652	AVX656	AVX658	AVX658
°	°D	E	-	AVX668	AVX668	AVX668	AVX669	-	AVX670
°	D	°	-	AVX651	AVX652	AVX652	AVX654	AVX658	AVX658
°	T	°	-	AVX652	AVX655	AVX655	AVX657	-	AVX662
L	°	°	AVX651	AVX651	AVX652	AVX652	AVX656	AVX658	AVX658
L	°D	E	-	AVX668	AVX668	AVX668	AVX669	-	AVX670
L	D	°	-	AVX651	AVX652	AVX652	AVX654	AVX658	AVX658
L	T	°	-	AVX652	AVX655	AVX655	AVX657	-	AVX662

Version	Heat recovery	Evaporator	1602	1802	2002	2202	2502	2802
°	°	°	AVX658	AVX659	AVX667	AVX661	AVX661	AVX661
°	°	E	AVX670	AVX670	AVX671	AVX672	AVX672	AVX672
°	D	°E	-	-	-	-	-	-
°	T	°	-	-	-	-	-	-
L	°	°	AVX658	AVX659	AVX667	AVX661	AVX661	AVX661
L	°	E	AVX670	AVX670	AVX671	AVX672	AVX672	AVX672
L	D	°E	-	-	-	-	-	-
L	T	°	-	-	-	-	-	-

- not available

Power factor correction

Ver	0601	0701	0801	0901	1101	1202	1402
°L	-	RIF161	RIF161	RIF201	RIF241	-	RIF161 x2

The accessory cannot be fitted on the configurations indicated with -
A grey background indicates the accessory must be assembled in the factory

Ver	1602	1802	2002	2202	2502	2802
°L	RIF161 x2	RIF201 x 2	RIF201+RIF241	RIF241 x2	RIF301 x2	RIF301 x2

A grey background indicates the accessory must be assembled in the factory

Acoustic kit

Ver	0601	0701	0801	0901	1101	1202	1402	1602	1802	2002	2202	2502	2802
L	AKW (1)	AKW (1)	AKW (1)	AKW (1)	AKW (1)	AKW (1)	AKW (1)	AKW (1)	AKW (1)	AKW (1)	AKW (1)	AKW (1)	AKW (1)

(1) Available only in low noise version

A grey background indicates the accessory must be assembled in the factory

CONFIGURATOR

Field	Description
1,2,3	HWS
4,5,6,7	Size 0601, 0701, 0801, 0901, 1101, 1202, 1402, 1602, 1802, 2002, 2202, 2502, 2802
8	Operating field
°	Standard mechanic thermostatic valve
X	Electronic thermostatic expansion valve
9	Model
°	Heat pump reversible on the water side
10	Heat recovery
°	Without heat recovery
D	With desuperheater (1)
T	With total recovery (2)
11	Version
°	Standard
L	Standard silenced

Field	Description
12	Evaporator
°	Standard
E	Evaporating unit (3)
13	Power supply
°	400V ~ 3 50Hz with fuses
2	230V ~ 3 50Hz with fuses
4	230V ~ 3 50Hz with magnet circuit breakers
5	500V ~ 3 50Hz with fuses
8	400V ~ 3 50Hz with magnet circuit breakers
9	500V ~ 3 50Hz with magnet circuit breakers

(1) In cooling mode, a water temperature no lower than 35°C must always be guaranteed on the heat exchanger inlet. The desuperheater is not available for size for 0601 to 1202 and from 1602 to 2802.

(2) The desuperheater and total recovery are not available for sizes 0601 and 1202 and size up 1602 to 2802; T are not compatible with E

(3) Shipped with holding charge only. Option not available for size 0601 and 1202.

PERFORMANCE SPECIFICATIONS

HWS - °L

Size			0601	0701	0801	0901	1101	1202	1402	1602	1802	2002	2202	2502	2802
Cooling performance 12 °C / 7 °C (1)															
Cooling capacity	°L	kW	146,7	178,8	212,7	233,7	293,7	293,7	356,6	422,6	469,5	528,5	587,4	662,4	714,3
Input power	°L	kW	31,7	38,0	43,2	49,2	59,7	63,5	76,8	86,5	101,0	110,7	120,5	137,7	148,2
Cooling total input current	°L	A	56,0	66,0	74,0	82,0	101,0	112,0	132,0	148,0	164,0	184,0	203,0	233,0	233,0
EER	°L	W/W	4,63	4,70	4,92	4,75	4,92	4,62	4,64	4,88	4,65	4,77	4,87	4,81	4,82
Water flow rate source side	°L	l/h	30474	37085	43795	48419	60454	60948	73996	86906	97348	109046	120744	136364	146849
Pressure drop source side	°L	kPa	40	27	27	26	31	53	50	55	58	62	67	75	88
Water flow rate system side	°L	l/h	25256	30754	36596	40204	50513	50513	61337	72676	80751	90888	101025	113911	122845
Pressure drop system side	°L	kPa	29	20	20	19	23	38	36	40	41	45	48	53	62
Heating performance 40 °C / 45 °C (2)															
Heating capacity	°L	kW	163,9	199,3	234,8	260,1	324,0	327,5	397,5	465,7	522,8	584,8	646,9	730,9	799,6
Input power	°L	kW	38,0	45,4	51,6	58,8	71,4	76,3	92,2	104,0	121,3	133,2	145,1	165,9	181,5
Heating total input current	°L	A	66,0	78,0	88,0	97,0	120,0	133,0	157,0	176,0	195,0	218,0	241,0	277,0	280,0
COP	°L	W/W	4,31	4,39	4,55	4,42	4,54	4,29	4,31	4,48	4,31	4,39	4,46	4,41	4,40
Water flow rate source side	°L	l/h	36968	45016	53566	58847	73936	73936	89780	106378	118198	133036	147873	166735	182932
Pressure drop source side	°L	kPa	62	43	43	41	49	81	77	86	88	96	103	114	137
Water flow rate system side	°L	l/h	28421	34581	40752	45134	56255	56843	69010	80851	90770	101543	112315	126902	138328
Pressure drop system side	°L	kPa	35	23	23	23	27	46	43	48	50	54	58	65	79

(1) Date 14511:2022; Water user side 12 °C / 7 °C; Water source side 30 °C / 35 °C

(2) Date 14511:2022; Water user side 40 °C / 45 °C; Water source side 10 °C / 7 °C

Performance specifications Evaporating units

HWS - E

Size			0601	0701	0801	0901	1101	1202	1402	1602	1802	2002	2202	2502	2802
Evaporator: E															
Cooling performance 12 °C / 7 °C (1)															
Cooling capacity	°L	kW	-	163,0	192,0	212,0	263,0	-	326,0	385,0	428,0	481,0	539,0	601,0	676,0
Input power	°L	kW	-	41,0	47,0	54,0	66,0	-	82,0	93,0	108,0	120,0	132,0	146,0	159,0
Cooling total input current	°L	A	-	72,0	81,0	90,0	113,0	-	144,0	162,0	180,0	204,0	226,0	254,0	272,0
EER	°L	W/W	-	3,98	4,09	3,93	3,98	-	3,98	4,14	3,96	4,01	4,08	4,12	4,25
Water flow rate system side	°L	l/h	-	28005	32988	36424	45186	-	56011	66147	73535	82641	92606	103259	116144
Pressure drop system side	°L	kPa	-	20	20	19	23	-	36	40	41	45	48	53	62

(1) Service side water 12 °C / 7 °C; Condensing temperature 45 °C

ENERGY INDICES (REG. 2016/2281 EU)

Size			0601	0701	0801	0901	1101	1202	1402	1602	1802	2002	2202	2502	2802
SEER - 12/7 (EN14825: 2018) (1)															
SEER	°L	W/W	5,01	5,28	5,57	5,43	5,59	5,36	5,42	5,39	5,17	5,25	5,30	5,20	5,12
Seasonal efficiency	°L	%	197,4%	208,2%	219,8%	214,2%	220,6%	211,4%	213,6%	212,6%	203,8%	207,0%	209,0%	205,0%	201,8%
UE 813/2013 performance in average ambient conditions (average) - 55 °C - Pdesignh ≤ 400 kW (2)															
Pdesignh	°L	kW	215	257	293	330	-	-	-	-	-	-	-	-	-
SCOP	°L	W/W	4,55	4,60	4,73	4,58	-	-	-	-	-	-	-	-	-
nsh	°L	%	174,0%	176,0%	181,0%	175,0%	-	-	-	-	-	-	-	-	-

(1) Calculation performed with VARIABLE water flow rate and VARIABLE outlet temperature.

(2) Efficiencies for average temperature applications (55 °C)

ELECTRIC DATA

Size			0601	0701	0801	0901	1101	1202	1402	1602	1802	2002	2202	2502	2802
Electric data															
Maximum current (FLA)	°L	A	105,0	124,0	144,0	162,0	182,0	210,0	248,0	288,0	324,0	344,0	364,0	430,0	430,0
Peak current (LRA)	°L	A	180,0	163,0	192,0	229,0	300,0	285,0	287,0	336,0	391,0	462,0	482,0	575,0	575,0

GENERAL TECHNICAL DATA

Size			0601	0701	0801	0901	1101	1202	1402	1602	1802	2002	2202	2502	2802
Compressor															
Type	°L	type							Screw						
Compressor regulation	°L	Type							On-Off						
Number	°L	no.	1	1	1	1	1	2	2	2	2	2	2	2	2
Circuits	°L	no.	1	1	1	1	1	2	2	2	2	2	2	2	2
Refrigerant	°L	type							R134a						
System side heat exchanger															
Type	°L	type							Brazed plate						
Number	°L	no.	1	1	1	1	1	1	1	1	1	1	1	1	1
Source side heat exchanger															
Type	°L	type							Brazed plate						
Number	°L	no.	1	1	1	1	1	1	1	1	1	1	1	1	1
System side hydraulic connections															
Connections (in/out)	°L	Type							Grooved joints						
Sizes (in/out)	°L	Ø							3"						
Source side hydraulic connections															
Connections (in/out)	°L	Type							Grooved joints						
Sizes (in/out)	°L	Ø							3"						
Sound data calculated in cooling mode (1)															
Sound power level	°	dB(A)	85,0	86,0	86,0	86,0	92,0	88,0	89,0	89,0	89,0	93,0	95,0	95,0	95,0
	L	dB(A)	77,0	78,0	78,0	78,0	84,0	80,0	81,0	81,0	81,0	85,0	87,0	87,0	87,0
Sound pressure level (10 m)	°	dB(A)	53,2	54,2	54,2	54,2	60,2	56,2	57,2	57,2	57,2	61,1	63,1	63,1	63,1
	L	dB(A)	45,2	46,2	46,2	46,2	52,2	48,1	49,1	49,1	49,1	53,1	55,1	55,1	55,1

(1) Sound power calculated on the basis of measurements made in accordance with UNI EN ISO 9614-2, as required for Eurovent certification. Sound pressure (cold functioning) measured in free field, 10m away from the unit external surface (in compliance with UNI EN ISO 3744).

DIMENSIONS

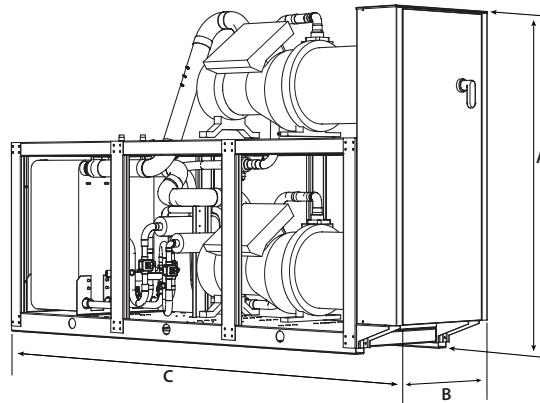

Size			0601	0701	0801	0901	1101	1202	1402	1602	1802	2002	2202	2502	2802
Dimensions and weights															
A	°	mm	1775	1775	1775	1775	1775	1975	1975	1975	2005	1985	2065	2065	2065
	L	mm	1775	1775	1775	1775	1775	2120	2120	2120	2120	2120	2120	2120	2120
B	°L	mm	810	810	810	810	810	810	810	810	810	810	810	810	810
	°L	mm	2960	2960	2960	2960	3360	2960	2960	2960	2960	3360	3360	3360	3360
Empty weight	°L	kg	1101	1251	1301	1357	1788	1738	2028	2097	2169	2598	3000	3095	3095

Aermec reserves the right to make any modifications deemed necessary. All data is subject to change without notice. Aermec does not assume responsibility or liability for errors or omissions.

Aermec S.p.A.

Via Roma, 996 - 37040 Bevilacqua (VR) - Italia
Tel. 0442633111 - Telefax 044293577
www.aermec.com