

# CL 025-200

## Air-water chiller

Cooling capacity 5,8 ÷ 41 kW



- Standard version
- Version with Integrated hydronic kit system side
- Fan Plug-fan



### DESCRIPTION

Chillers for indoor installation for chilled water production with scroll compressors, plugfan fans, external copper coils with aluminum louvers. The base, the structure and the panels are made of galvanized steel treated with polyester paint RAL 9003.

### VERSIONS

- ° Standard
- A With storage tank and pump
- P With pump

### FEATURES

#### Operating field

Operation at full load up to 46°C external air temperature. Unit can produce chilled water up to -10°C.

#### EC fan plug-fan

The units are equipped with plug-fans and inverter motors coupled directly with the fan, with the electronic condensation control as standard, which adjusts the air flow according to the actual system requirements, with benefits in terms of consumption and noise reduction. In addition, compared to conventional centrifugal fans, they do not feature belt and pulley transmission, resulting in easy flow adjustment, compactness, versatility, easy maintenance and no vibrations.

#### Air supply

Horizontal or vertical, adjustable during installation for all sizes. Directional air discharge hood:  
 — plastic for sizes 050 to 090  
 — galvanised steel for the other sizes

#### Version with Integrated hydronic kit

Integrated hydronic kit containing the main hydraulic components; available with various configurations to obtain a solution that allows you to save money and to facilitate installation.

#### Hot water production

In the configuration with desuperheater, it is also possible to produce free-hot water.

### MODUCONTROL CONTROL

The command panel of the unit allows the rapid setting of the working parameters of the machine, and their visualisation. The display consists of 4 figures and various LEDs for indicating the type of operational mode, the visualisation of the parameters set and of any alarms triggered. The card stores all the default settings and any modifications.

The regulation using an outside air temperature sensor allows a dynamic control of the water temperature produced by increasing the energy efficiency of the system.

### ACCESSORIES

**AERBAC-MODU:** Ethernet communication Interface for protocols Bacnet/IP, Modbus TCP/IP, SNMP. The accessory is supplied with the unit and must be installed on an external electrical panel.

**AERLINK:** Aerlink is a WiFi gateway with an RS485 serial port that allows a wide range of Aermec products (heat pumps/chillers/system controllers) equipped with this interface to connect easily and securely to a Wi-Fi network. It works both as an access point (AP access point) and as a client (WiFi Station), it can be connected to a single generator or system centraliser, allowing anyone to easily integrate them into any network. Thanks to the AerApp and AerPlants apps, which can be used on Android and iOS platforms, the remote management of the air conditioning systems developed by Aermec becomes intuitive and simple.

**AERSET:** It makes it possible to automatically compensate for the operation setting of the unit to which it is connected, based on a 0-10V MODBUS input signal. Mandatory accessory MODU-485BL.

**MODU-485BL:** RS-485 interface for supervision systems with MODBUS protocol.

**MULTICONTROL:** Allows the simultaneous control of several units (up to 4), installed in the same hydraulic system.

**PR3:** Simplified remote panel. This makes it possible to carry out the unit's basic controls with the signalling of alarms. Can be made remote with shielded cable up to 150 m.

**SGD:** Electronic expansion that enables connecting to the photovoltaic system and heat pumps to accumulate heat in the DHW tank or in the heating system during the photovoltaic production phase and release it at times when heating demand is highest.

**SPLW:** System water temperature sensor. In most cases the loose supplied sensors for each chiller/heat pump are sufficient. In cases of a common flow/return header this sensor can be used to control the common system supply water temperature for the chillers connected to the header, or it can be used for temperature monitoring

**PR4:** Remote panel with LCD display and touch keyboard that allows carrying out the basic controls, the programming of time ranges and the signalling of the alarms of a single unit.

■ For the installation of the PR4 remote panel, the MODU-485BL communication interface is indispensable.

**VT:** Anti-vibration supports.

**CLPA:** Galvanised steel plenum to be installed on the condenser coil, facilitates duct installations.

### FACTORY FITTED ACCESSORIES

**DRE:** Electronic device for peak current reduction.

**KR:** Anti-freeze electric heater for the plate heat exchanger.

**GPCL:** Protection grille for the source side exchange coil.

### COMPATIBILITY WITH VMF SYSTEM

For more information about VMF system, refer to the dedicated documentation.

## ACCESSORIES COMPATIBILITY

### Accessories

Model	Ver	025	030	040	050	070	080	090	100	150	200
AERBAC-MODU	°A,P	*	*	*	*	*	*	*	*	*	*
AERLINK	°A,P	*	*	*	*	*	*	*	*	*	*
AERSET	°A,P	*	*	*	*	*	*	*	*	*	*
MODU-485BL	°A,P	*	*	*	*	*	*	*	*	*	*
MULTICONTROL	°A,P	*	*	*	*	*	*	*	*	*	*
PR3	°A,P	*	*	*	*	*	*	*	*	*	*
SGD	°A,P	*	*	*	*	*	*	*	*	*	*
SPLW (1)	°A,P	*	*	*	*	*	*	*	*	*	*

(1) Probe required for MULTICONTROL to manage the secondary circuit system.

### Remote panel

Model	Ver	025	030	040	050	070	080	090	100	150	200
PR4	°A,P	*	*	*	*	*	*	*	*	*	*

For the installation of the PR4 remote panel, the MODU-485BL communication interface is indispensable.

### Antivibration

Ver	025	030	040	050	070	080	090	100	150	200
°P	VT9	VT9	VT9	VT9	VT9	VT9	VT9	VT15	VT15	VT15
A	VT15A	VT15A	VT15A	VT15A	VT15A	VT15A	VT15A	VT15	VT15	VT15

### Galvanised steel plenum

Ver	025	030	040	050	070	080	090	100	150	200
°A,P	CLPA1 (1)	CLPA1 (1)	CLPA2 (2)	CLPA2 (2)	CLPA2 (2)	CLPA2 (2)	CLPA2 (2)	CLPA3	CLPA3	CLPA3

(1) Not compatible with the GPCL1 accessory

(2) Not compatible with the GPCL2 accessory

### Device for peak current reduction

Ver	025	030	040	050	070	080	090	100	150	200
°A,P	DRES (1)	DRES (1)	DRES (1)	DRES (1)	DRES (1)	DRES (1)	DRES (1)	DRES x 2 (1)	DRES x 2 (1)	DRES x 2 (1)

(1) Only for supplies of 400V 3N ~ 50Hz and 400V 3 ~ 50Hz. x 2 or x 3 (if present) indicates the quantity to be ordered.

A grey background indicates the accessory must be assembled in the factory

### Antifreeze electric heater

Ver	025	030	040	050	070	080	090	100	150	200
°A,P	KR2	KR2	KR2	KR2	KR2	KR2	KR2	KR100	KR100	KR100

A grey background indicates the accessory must be assembled in the factory

### Anti-intrusion grid

Ver	025	030	040	050	070	080	090	100	150	200
°A,P	GPCL1	GPCL1	GPCL2	GPCL2	GPCL2	GPCL2	GPCL2	GPCL3	GPCL3	GPCL3

A grey background indicates the accessory must be assembled in the factory

## CONFIGURATOR

Field	Description
1,2	<b>CL</b>
3,4,5	<b>Size</b> 025, 030, 040, 050, 070, 080, 090, 100, 150, 200
6	<b>Model</b>
°	Cooling only
7	<b>Execution</b>
L	Silenced
°	Standard
8	<b>Version</b>
°	Standard
A	With storage tank and pump
P	With pump
9	<b>Heat recovery</b>
D	With desuperheater (1)
°	Without heat recovery
10	<b>Coils</b>
R	Copper pipes-copper fins
S	Copper pipes-Tinned copper fins

Field	Description
V	Copper pipes-Coated aluminium fins
°	Copper-aluminium
11	<b>Operating field</b>
Y	Low temperature mechanic thermostatic valve (2)
Z	Low temperature mechanic thermostatic valve (3)
°	Standard mechanic thermostatic valve (4)
12	<b>Evaporator</b>
C	Motocondensing unit
°	Standard
13	<b>Power supply</b>
M	230V ~ 50Hz (5)
°	400V 3N ~ 50Hz (6)

(1) It is only available in size CL 050 ÷ 200; If the unit is also fitted with one of the low temperature valves in addition to the desuperheater, it is necessary to always guarantee a water temperature of 35°C at the inlet of the desuperheater.

(2) Water produced from 0 °C ÷ -10 °C

(3) Water produced from 0 °C ÷ 4 °C

(4) Water produced from 4 °C ÷ 18 °C

(5) Only for CL 025 ÷ 040 sizes

(6) Only for CL 025 ÷ 200 sizes

## PERFORMANCE SPECIFICATIONS

### CL °/L - (version °) - (400V 3N ~ 50Hz / 230V ~ 50Hz)

Size		025	030	040	050	070	080	090	100	150	200
<b>Cooling performance 12 °C / 7 °C (1)</b>											
Cooling capacity	kW	5,8	7,1	8,8	12,7	16,3	18,4	20,2	26,3	33,0	40,6
Input power	kW	2,2	2,6	3,5	4,3	5,5	6,7	6,8	8,8	11,3	14,4
Cooling total input current - 400V	A	4,8	5,1	7,5	8,4	10,0	12,0	13,0	17,0	19,0	25,0
Cooling total input current - 230V	A	10,0	13,0	17,0	-	-	50,0	-	-	-	-
EER	W/W	2,70	2,72	2,50	2,98	3,00	2,76	2,98	2,99	2,91	2,82
Water flow rate system side	l/h	1008	1233	1523	2189	2817	3166	3484	4533	5695	7001
Pressure drop system side	kPa	19	26	25	27	29	30	29	45	53	72

(1) Data EN 14511:2022; Heat exchanger water (services side) 12°C / 7°C; outside air 35°C

### CL °/L - (versions A/P) - (400V 3N ~ 50Hz / 230V ~ 50Hz)

Size		025	030	040	050	070	080	090	100	150	200
<b>Cooling performance 12 °C / 7 °C (1)</b>											
Cooling capacity	kW	5,9	7,2	8,9	12,8	16,5	18,5	20,4	26,5	33,4	41,0
Input power	kW	2,1	2,6	3,5	4,2	5,4	6,6	6,8	8,9	11,6	14,6
Cooling total input current - 400V	A	5,1	5,4	7,9	9,0	11,0	13,0	13,0	18,0	21,0	27,0
Cooling total input current - 230V	A	11,0	14,0	18,0	-	-	-	-	-	-	-
EER	W/W	2,76	2,78	2,55	3,02	3,04	2,80	3,02	2,97	2,87	2,81
Water flow rate system side	l/h	1008	1233	1523	2189	2817	3166	3484	4533	5695	7001
Useful head system side	kPa	71	62	61	73	66	61	58	83	131	122

(1) Data EN 14511:2022; Heat exchanger water (services side) 12°C / 7°C; outside air 35°C

## ELECTRIC DATA

Size			025	030	040	050	070	080	090	100	150	200
<b>Power supply: °</b>												
<b>Electric data</b>												
Maximum current (FLA)	°	A	11,0	11,6	12,6	13,6	15,4	17,0	20,4	27,4	30,8	40,8
	A,P	A	11,4	12,0	13,0	14,4	16,1	17,7	21,1	29,3	33,8	43,8
Peak current (LRA)	°	A	44,6	40,6	71,6	77,2	77,2	77,2	105,2	90,9	92,6	125,6
	A,P	A	45,0	41,0	72,0	77,9	77,9	77,9	105,9	92,8	95,6	128,6
<b>Power supply: M</b>												
<b>Electric data</b>												
Maximum current (FLA)	°	A	22,0	25,0	25,0	-	-	-	-	-	-	-
	A,P	A	22,6	25,6	25,7	-	-	-	-	-	-	-
Peak current (LRA)	°	A	67,0	88,0	118,0	-	-	-	-	-	-	-
	A,P	A	67,6	88,6	118,6	-	-	-	-	-	-	-

## GENERAL TECHNICAL DATA

Size			025	030	040	050	070	080	090	100	150	200
<b>Compressor</b>												
Type	°A,P	type	Scroll									
Compressor regulation	°A,P	Type	On-off									
Number	°A,P	no.	1	1	1	1	1	1	1	2	2	2
Circuits	°A,P	no.	1	1	1	1	1	1	1	1	1	1
Refrigerant	°A,P	type	R410A									
Refrigerant charge (1)	°A,P	kg	1,5	2,7	2,7	4,0	4,0	4,0	4,0	5,5	7,5	7,5
<b>System side heat exchanger</b>												
Type	°A,P	type	Braze plate									
Number	°A,P	no.	1	1	1	1	1	1	1	1	1	1
<b>Hydraulic connections</b>												
Connections (in/out)	°A,P	Type	Gas - F									
Size (in)	°A,P	Ø	1¼									
Size (out)	°A,P	Ø	1¼									
<b>Fan</b>												
Type	°A,P	type	Plug-fan									
Fan motor	°A,P	type	Inverter									
Number	°A,P	no.	1	1	1	1	1	1	1	2	2	2
Air flow rate	°A,P	m <sup>3</sup> /h	4000	4000	4000	6500	6500	6500	7500	10000	12000	12000
High static pressure	°A,P	Pa	50	50	50	50	50	50	50	50	50	50
<b>Intake plus machine body</b>												
Sound power level	°A,P	dB(A)	78,0	78,0	78,0	73,0	73,0	73,0	76,0	74,0	79,0	79,0
Sound pressure level in cooling mode (10 m)	°A,P	dB(A)	46,0	46,0	46,0	41,0	41,0	41,0	44,0	42,0	47,0	47,0
<b>Machine exhaust</b>												
Sound power level	°A,P	dB(A)	78,0	78,0	78,0	78,0	78,0	78,0	81,0	78,0	83,0	83,0
Sound pressure level in cooling mode (10 m)	°A,P	dB(A)	46,0	46,0	46,0	46,0	46,0	46,0	49,0	47,0	52,0	52,0

(1) The load indicated in the table is an estimated and preliminary value. The final value of the refrigerant load is indicated on the unit's technical label. For further information contact the office.

## DISCHARGE HOOD POSSIBLE CONFIGURATIONS

CL 025 ÷ 090

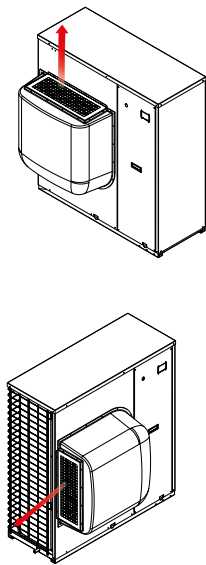

CL 100 ÷ 200

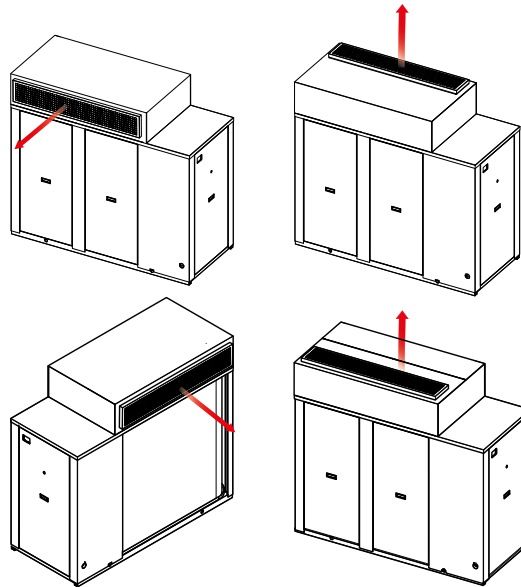

Air supply  
Horizontal or vertical, adjustable during installation for all sizes.  
Directional air discharge hood:

— plastic for sizes 050 to 090  
— galvanised steel for the other sizes

## DIMENSIONS

CL 025 ÷ 090

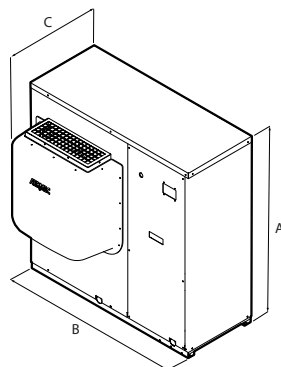

CL 100 ÷ 200

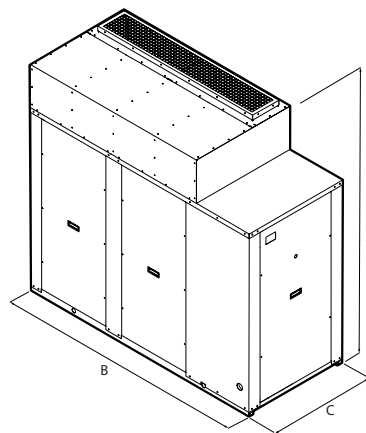

Size			025	030	040	050	070	080	090	100	150	200
<b>Dimensions and weights</b>												
A	°A,P	mm	1028	1281	1281	1281	1281	1281	1281	1674	1674	1674
	°P	mm	1005	1006	1006	1160	1160	1160	1160	1897	1897	1897
B	A	mm	1366	1458	1458	1610	1610	1610	1610	1897	1897	1897
	°A,P	mm	702	754	754	798	798	798	798	801	801	801
C	°	kg	127	160	160	208	210	210	212	469	471	475
	A	kg	157	201	201	252	260	260	256	532	537	542
Empty weight	P	kg	133	166	166	217	225	225	221	482	487	492

Aermec reserves the right to make any modifications deemed necessary.  
All data is subject to change without notice. Aermec does not assume  
responsibility or liability for errors or omissions.

**Aermec S.p.A.**  
Via Roma, 996 - 37040 Bevilacqua (VR) - Italia  
Tel. 0442633111 - Telefax 044293577  
www.aermec.com