

BHP

Reversible air/water split heat pump

Cooling capacity 3,2 ÷ 11,5 kW – Heating capacity 4,0 ÷ 16,0 kW

- Indoor unit available in two versions, with and without DHW
- New R32 ecological refrigerant gas
- Production of hot water up to 60 °C
- Anti-legionella function
- Multi-language touch-screen control panel



DESCRIPTION

BHP It's the new "split" type inverter heat pump system, more efficient than standard boiler systems as it guarantees sustainable, efficient heating, cooling and domestic hot water supply in every season.

BHP is designed to meet the needs of both the new constructions market and the renovation market, replacing or working alongside conventional boilers.

The system can be installed in systems with any hydronic terminal, and is already supplied with the main hydraulic components, thus facilitating final installation.

The indoor unit comes in two versions:

- BHP_W **wall-mounting**, without DHW storage tank but complete with a 3-way DHW-system diverting valve. **For the production of DHW it is mandatory to combine it with a domestic hot water storage tank Aermec compatible.**
- **BHP_F with base**, complete with DHW storage tank.

FEATURES

Main hydraulic components

BHP outdoor unit

- inverter compressor,
- finned pack heat exchanger with copper pipes and aluminium louvers, with protective golden fin treatment,
- economizer,
- electronic valve,
- DC axial brushless fan,
- electric heater for the base.

BHP_W wall indoor unit

- plate heat exchanger,
- flow switch,
- inverter pump,
- expansion tank,
- drain valve,
- safety valve,
- Electric resistance system side,
- 3 way valve,
- DHW-system connections,
- water filter supplied (**mandatory installation**).

BHP_F indoor base unit

- plate heat exchanger,
 - flow switch,
 - inverter pump,
 - expansion tank,
 - drain valve,
 - safety valve,
 - Electric resistance system side,
 - 3 way valve,
 - DHW-system connections,
 - water filter supplied (**mandatory installation**),
 - DHW storage tank of 185 litres with coil and supplementary electric heater, and anti-legionella function,
 - **tank with Titanium electronic sacrificial anode.**
- The indoor and outdoor units are connected by means of suitably sized cooling lines (supplied by the installer).
Cooling circuit use R32 (A2L) refrigerant with low GWP.

Operating limits

Full load operation down to -25°C (outside air temperature in winter), and up to 48°C in summer.

Regulations

Adjustment via **multi-language touch-screen control panel**:

- management of a 3-way diverting valve for the production of domestic hot water,
- management of a 2 way valve (not supplied) for shutting off part of the system,
- weekly programming in time periods,
- **auto-restart** function,
- emergency operation,
- function **quick water heating** for a quick heating of domestic hot water
- forced operating **mode**,
- intelligent operation **based on weather conditions** for climate adjustment,
- **quiet** function for reduced noise operation (programmable with a timer),
- **Anti-freeze** function,
- condensation check,

- when the **anti-legionella cycle** is activated (it's easily set via the control panel), the whole tank is heated once a week to a temperature (max. 70 °C) that weakens the bacteria responsible for the infection,
- pre heating **function of the floor** to pre-heat the floor system before unit commissioning.



Special golden fin coil

Unlike normal batteries, this special golden epoxy coating silicon free is able to protect the heat exchanger against rust and corrosion, in areas where the air has a high salt content.

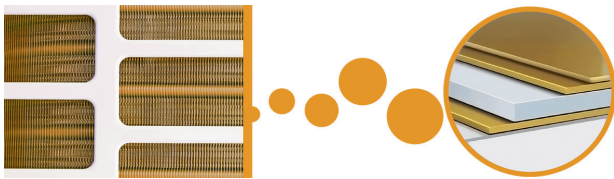

Smart APP Ewpe

The system is equipped standard with the Wi-Fi module; using this module and the app for iOS and Android devices (available free on Apple Store and Google Play, the system can be directly controlled from a distance on your smartphone or tablet. Remote control is possible via Cloud, using a wireless router connected to the Internet.



ACCESSORIES

IC-2P: Connector for communication via Mod Bus or VMF -485LINK. Accessory compulsory if combined with VMF-485LINK, or for third party supervision systems.

VMF-485LINK: Expansion to interface the unit with the VMF communication protocol, making it possible to manage it from the VMF-E5 or VMF-E6 supervisors.

LOGATW: Diagnostic tool for air-water heat pumps.

DHWT300S: (220-240V~50Hz) DHW storage tank in enamelled steel. Single-phase power supply, tank capacity 300 litres with main and secondary coils and 3 kW back-up electric heater. Magnesium sacrificial anode. Indoor installation.

For the production of DHW it is mandatory to combine it with BHP_W.

Compatibility with VMF system

For more information about VMF system, refer to the dedicated documentation.

Connection with VMF-485LINK

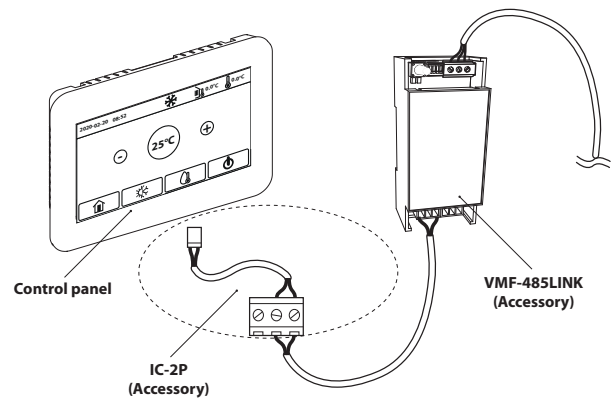

Connection with third party supervision systems

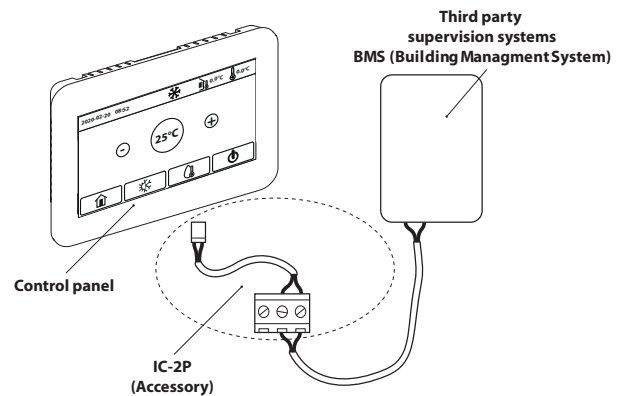

Compatibility with DHW storage tank

	BHP060W	BHP100W	BHP100WT	BHP160W	BHP160WT
DHWT300S

BHP_W: DOMESTIC HOT WATER STORAGE TANK CONNECTION AND CONNECTION TO THE FLOOR SYSTEM AND FCU

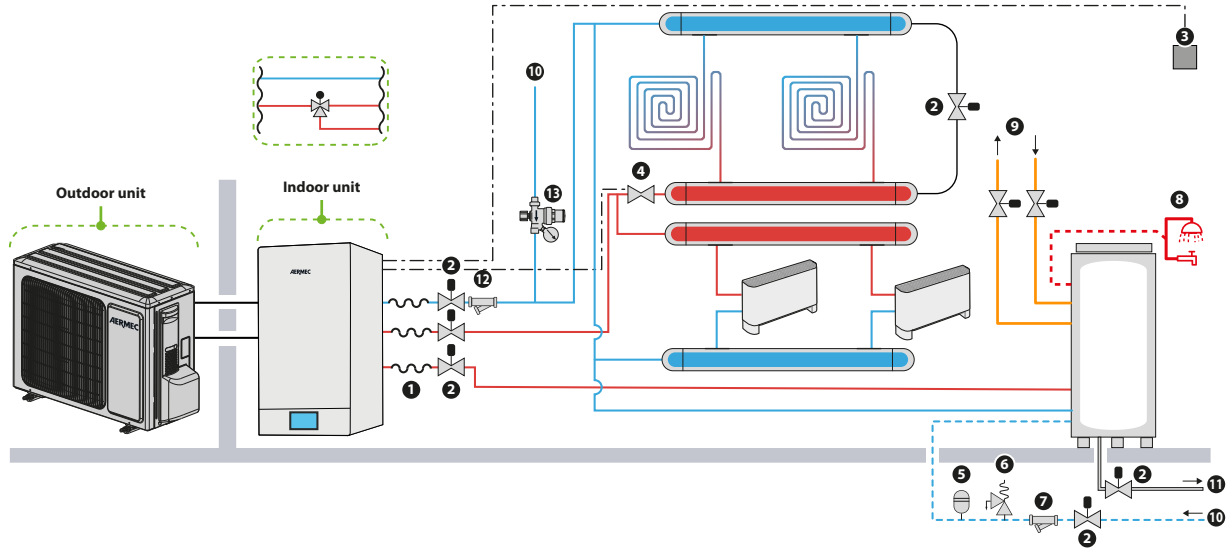

HYDRAULIC COMPONENTS SUPPLIED AS STANDARD IN THE INDOOR UNIT

- Plate heat exchanger
- Flow switch
- Inverter circulator
- Expansion vessel
- Drain valve
- Pressure relief valve
- Electric resistance system side
- 3 way valve
- DHW-system connections

SUPPLIED HYDRAULIC COMPONENTS

12. Water filter supplied (**mandatory installation**)

HYDRAULIC COMPONENTS RECOMMENDED OUTSIDE THE UNIT (AT THE INSTALLER'S RESPONSIBILITY)

1. Anti-vibration joints
2. Shut-off tap
3. Ambient thermostat
4. 2 way valve
5. Expansion tank **NOT supplied**
6. Safety valve **supplied with Aermec ACS storage system compatible (installation is mandatory)**
7. Water filter **NOT supplied (installation is mandatory)**
8. Hot domestic water
9. Auxiliary heat sources
10. Aqueduct
11. Storage discharge
13. Loading unit

BHP_F: CONNECTION TO THE FLOOR SYSTEM AND FCU

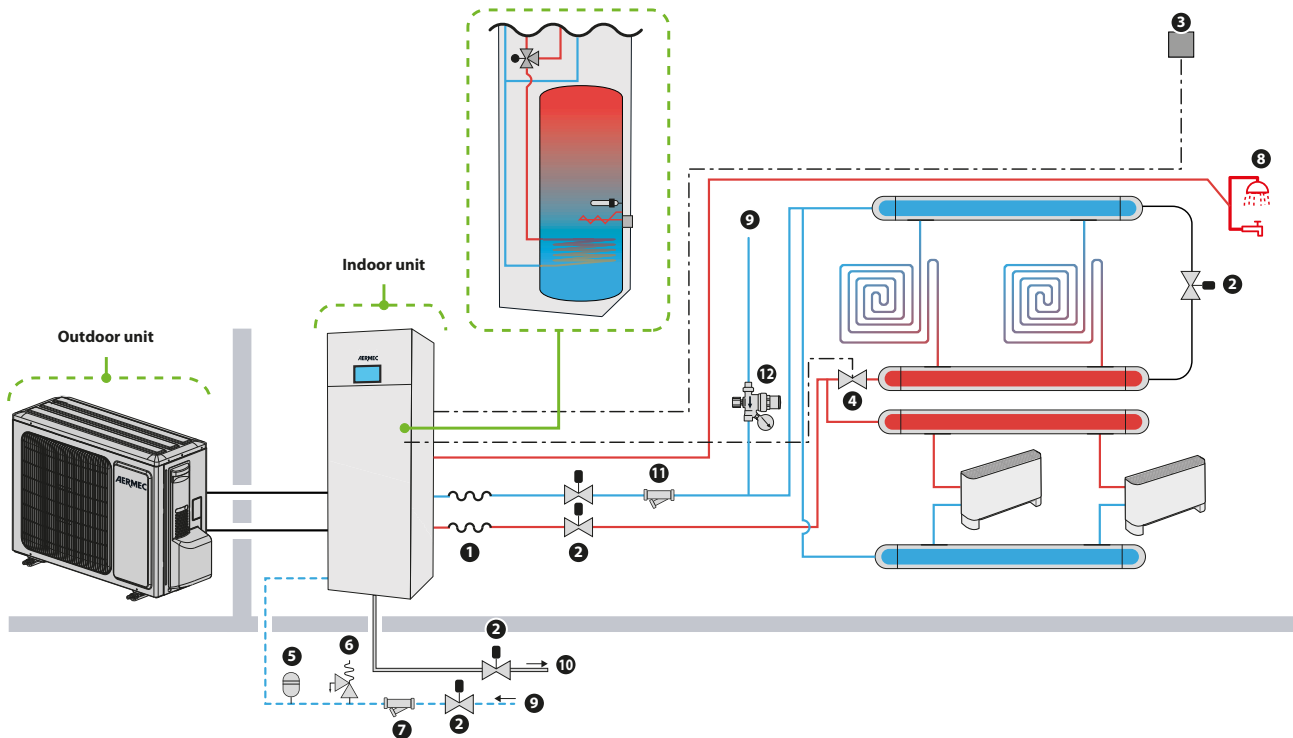

HYDRAULIC COMPONENTS SUPPLIED AS STANDARD IN THE INDOOR UNIT

- Plate heat exchanger
- Flow switch
- Inverter pump
- Expansion vessel
- Drain valve
- Pressure relief valve
- Electric resistance system side
- 3 way valve
- DHW-system connections

SUPPLIED HYDRAULIC COMPONENTS

11. Water filter supplied (mandatory installation)

HYDRAULIC COMPONENTS RECOMMENDED OUTSIDE THE UNIT (AT THE INSTALLER'S RESPONSIBILITY)

1. Anti-vibration joints
2. Shut-off tap
3. Ambient thermostat
4. 2 way valve
5. Expansion tank **NOT supplied**
6. Safety valve **NOT supplied (installation is mandatory)**
7. Water filter **NOT supplied (installation is mandatory)**
8. Hot domestic water
9. Aqueduct
10. Storage discharge
12. Loading unit

PERFORMANCE SPECIFICATIONS

Technical data Wall unit

Indoor unit		BHP060W	BHP060W	BHP100W	BHP100W	BHP160W	BHP160W	BHP160W
Outdoor unit		BHP040	BHP060	BHP080	BHP100	BHP120	BHP140	BHP160
Cooling performance 12 °C / 7 °C (1)								
Cooling capacity	kW	3,20	4,09	5,30	6,50	10,07	11,30	11,60
Input power	kW	0,94	1,28	1,73	2,27	3,65	4,04	4,38
EER	W/W	3,42	3,20	3,06	2,86	2,93	2,80	2,65
Water flow rate system side	l/h	550	703	912	1118	1840	1944	1995
Useful head system side	kPa	76	74	70	63	56	54	48
Heating performance 40 °C / 45 °C (2)								
Heating capacity	kW	4,00	5,90	8,00	9,50	12,40	14,50	16,10
Input power	kW	1,02	1,51	2,14	2,64	3,22	3,87	4,41
COP	W/W	3,92	3,91	3,74	3,60	3,85	3,75	3,65
Water flow rate system side	l/h	688	1015	1376	1634	2133	2494	2769
Useful head system side	kPa	74	67	51	36	45	26	11
Cooling performance 23 °C / 18 °C (3)								
Cooling capacity	kW	3,80	5,80	7,00	8,52	11,00	12,60	13,00
Input power	kW	0,82	1,32	1,75	2,25	2,50	3,41	3,60
EER	W/W	4,63	4,40	4,00	3,79	4,40	3,70	3,61
Water flow rate system side	l/h	655	992	1204	1465	1892	2167	2236
Useful head system side	kPa	74	67	60	46	54	40	34
Heating performance 30 °C / 35 °C (4)								
Heating capacity	kW	4,00	6,00	8,00	9,50	12,00	14,00	15,50
Input power	kW	0,78	1,20	1,70	2,07	2,40	2,98	3,44
COP	W/W	5,13	5,00	4,71	4,59	5,00	4,70	4,50
Water flow rate system side	l/h	688	1032	1376	1634	2064	2408	2666
Useful head system side	kPa	74	66	51	36	45	26	15
Heating performance 47 °C / 55 °C								
Heating capacity	kW	3,60	5,40	7,20	8,55	12,00	14,00	16,00
Input power	kW	1,40	2,16	3,05	3,72	3,81	4,52	5,42
COP	W/W	2,57	2,50	2,36	2,30	3,15	3,10	2,95
Useful head system side	kPa	27	19	19	12	65	60	53

(1) Data EN 14511:2022; Heat exchanger water (services side) 12°C / 7°C; outside air 35°C

(2) Data EN 14511:2022; System side water heat exchanger 40°C / 45°C; Outside air 7°C d.b. / 6°C w.b.

(3) Data EN 14511:2022; System side water heat exchanger 23°C / 18°C; External air 35°C

(4) Data EN 14511:2022; System side water heat exchanger 30°C / 35°C; External air 7°C d.b. / 6°C w.b.

Three-phase Wall unit technical data

Indoor unit		BHP100WT	BHP100WT	BHP160WT	BHP160WT	BHP160WT
Outdoor unit		BHP080T	BHP100T	BHP120T	BHP140T	BHP160T
Cooling performance 12 °C / 7 °C (1)						
Cooling capacity	kW	7,60	8,20	10,07	11,30	11,60
Input power	kW	2,35	2,73	3,65	4,04	4,38
EER	W/W	3,23	3,00	2,93	2,80	2,65
Water flow rate system side	l/h	1307	1410	1840	1944	1995
Useful head system side	kPa	66	58	56	54	48
Heating performance 40 °C / 45 °C (2)						
Heating capacity	kW	8,00	10,20	12,40	14,50	16,13
Input power	kW	1,93	2,55	3,22	3,87	4,42
COP	W/W	4,15	4,00	3,85	3,75	3,65
Water flow rate system side	l/h	1376	1720	2133	2494	2774
Useful head system side	kPa	60	45	45	26	11
Cooling performance 23 °C / 18 °C (3)						
Cooling capacity	kW	8,50	10,00	11,00	12,60	13,00
Input power	kW	1,74	2,33	2,50	3,41	3,60
EER	W/W	4,89	4,29	4,40	3,70	3,61
Water flow rate system side	l/h	1462	1720	1892	2167	2236
Useful head system side	kPa	54	41	54	40	34
Heating performance 30 °C / 35 °C (4)						
Heating capacity	kW	8,00	10,00	12,00	14,00	15,54
Input power	kW	1,63	2,15	2,40	2,98	3,45
COP	W/W	4,91	4,65	5,00	4,70	4,50
Water flow rate system side	l/h	1376	1754	2064	2408	2673
Useful head system side	kPa	60	46	46	26	14
Heating performance 47 °C / 55 °C						
Heating capacity	kW	8,00	10,00	12,00	14,00	16,00
Input power	kW	2,78	3,80	3,81	4,52	5,42
COP	W/W	2,88	2,63	3,15	3,10	2,95
Useful head system side	kPa	74	70	65	60	53

(1) Data EN 14511:2022; Heat exchanger water (services side) 12°C / 7°C; outside air 35°C

(2) Data EN 14511:2022; System side water heat exchanger 40 °C / 45 °C; Outside air 7 °C d.b. / 6 °C w.b.

(3) Data EN 14511:2022; System side water heat exchanger 23 °C / 18 °C; External air 35 °C

(4) Data EN 14511:2022; System side water heat exchanger 30 °C / 35 °C; External air 7 °C d.b. / 6 °C w.b.

Technical data base unit

Indoor unit		BHP060F	BHP060F	BHP100F	BHP100F
Outdoor unit		BHP040	BHP060	BHP080	BHP100
Cooling performance 12 °C / 7 °C (1)					
Cooling capacity	kW	3,20	4,09	5,30	6,50
Input power	kW	0,94	1,28	1,73	2,27
EER	W/W	3,42	3,20	3,06	2,86
Water flow rate system side	l/h	550	703	912	1118
Useful head system side	kPa	76	74	70	63
Heating performance 40 °C / 45 °C (2)					
Heating capacity	kW	4,00	5,90	8,00	9,50
Input power	kW	1,02	1,51	2,14	2,64
COP	W/W	3,92	3,91	3,74	3,60
Water flow rate system side	l/h	688	1015	1376	1634
Useful head system side	kPa	74	67	51	36
Cooling performance 23 °C / 18 °C (3)					
Cooling capacity	kW	3,80	5,80	7,00	8,52
Input power	kW	0,82	1,32	1,75	2,25
EER	W/W	4,63	4,40	4,00	3,79
Water flow rate system side	l/h	655	992	1204	1465
Useful head system side	kPa	74	69	60	46
Heating performance 30 °C / 35 °C (4)					
Heating capacity	kW	4,00	6,00	8,00	9,50
Input power	kW	0,78	1,20	1,70	2,07
COP	W/W	5,13	5,00	4,71	4,59
Water flow rate system side	l/h	688	1032	1376	1634
Useful head system side	kPa	74	66	51	36
Heating performance 47 °C / 55 °C					
Heating capacity	kW	3,60	5,40	7,20	8,55
Input power	kW	1,40	2,16	3,05	3,72
COP	W/W	2,57	2,50	2,36	2,30
Useful head system side	kPa	27	19	19	12

(1) Data EN 14511:2022; Heat exchanger water (services side) 12°C / 7°C; outside air 35°C

(2) Data EN 14511:2022; System side water heat exchanger 40 °C / 45 °C; Outside air 7 °C d.b. / 6 °C w.b.

(3) Data EN 14511:2022; System side water heat exchanger 23 °C / 18 °C; External air 35 °C

(4) Data EN 14511:2022; System side water heat exchanger 30 °C / 35 °C; External air 7 °C d.b. / 6 °C w.b.

ENERGY DATA

Energy data Wall unit

Indoor unit		BHP060W	BHP060W	BHP100W	BHP100W	BHP160W	BHP160W	BHP160W
Outdoor unit		BHP040	BHP060	BHP080	BHP100	BHP120	BHP140	BHP160
UE 811/2013 performance in average ambient conditions (average) - 35 °C - Pdesignh ≤ 70 kW (1)								
Pdesignh	kW	5	6	7	9	11	12	13
SCOP	W/W	4,66	4,54	4,60	4,60	4,63	4,65	4,61
ηsh	%	183,50	178,70	181,00	181,00	182,00	183,00	181,20
Efficiency energy class		A+++	A+++	A+++	A+++	A+++	A+++	A+++
UE 811/2013 performance in average ambient conditions (average) - 55 °C - Pdesignh ≤ 70 kW (2)								
Pdesignh	kW	5	5	7	8	11	13	13
SCOP	W/W	3,28	3,26	3,30	3,25	3,24	3,50	3,50
ηsh	%	128,10	127,40	129,00	127,00	126,40	137,00	137,00
Efficiency energy class		A++	A++	A++	A++	A++	A++	A++
Performance as combined heat generator								
Bleeding profile		XL	XL	XL	XL	XL	XL	XL
Efficiency energy class		A	A	A	A	A	A	A

(1) Efficiencies for low temperature applications (35 °C)

(2) Efficiencies for average temperature applications (55 °C)

Indoor unit		BHP060W	BHP060W	BHP100W	BHP100W	BHP160W	BHP160W	BHP160W
Outdoor unit		BHP040	BHP060	BHP080	BHP100	BHP120	BHP140	BHP160
Cooling capacity with low leaving water temp (UE n° 2016/2281)								
SEER	W/W	4,21	4,12	4,11	4,12	4,90	4,91	4,78
ηsc	%	165,00	162,00	161,00	162,00	193,00	193,00	188,00

Three-phase Wall unit energy data

Indoor unit		BHP100WT	BHP100WT	BHP160WT	BHP160WT	BHP160WT
Outdoor unit		BHP080T	BHP100T	BHP120T	BHP140T	BHP160T
UE 811/2013 performance in average ambient conditions (average) - 35 °C - Pdesignh ≤ 70 kW (1)						
Pdesignh	kW	8	9	11	12	13
SCOP	W/W	4,53	4,70	4,48	4,48	4,45
ηsh	%	178,10	185,20	176,00	176,00	175,00
Efficiency energy class		A+++	A+++	A+++	A+++	A+++
UE 811/2013 performance in average ambient conditions (average) - 55 °C - Pdesignh ≤ 70 kW (2)						
Pdesignh	kW	9	10	11	13	13
SCOP	W/W	3,48	3,49	3,23	3,38	3,38
ηsh	%	136,10	136,70	126,00	132,00	132,00
Efficiency energy class		A++	A++	A++	A++	A++
Performance as combined heat generator						
Bleeding profile		XL	XL	XL	XL	XL
Efficiency energy class		A	A	A	A	A

(1) Efficiencies for low temperature applications (35 °C)

(2) Efficiencies for average temperature applications (55 °C)

Indoor unit		BHP100WT	BHP100WT	BHP160WT	BHP160WT	BHP160WT
Outdoor unit		BHP080T	BHP100T	BHP120T	BHP140T	BHP160T
Cooling capacity with low leaving water temp (UE n° 2016/2281)						
SEER	W/W	4,11	4,12	4,74	4,76	4,64
ηsc	%	161,00	162,00	187,00	187,00	183,00

Energy data base unit

Indoor unit		BHP060F	BHP060F	BHP100F	BHP100F
Outdoor unit		BHP040	BHP060	BHP080	BHP100
UE 811/2013 performance in average ambient conditions (average) - 35 °C - Pdesignh ≤ 70 kW (1)					
Pdesignh	kW	5	6	7	9
SCOP	W/W	4,66	4,54	4,60	4,60
ηsh	%	183,50	178,70	181,00	181,00
Efficiency energy class		A+++	A+++	A+++	A+++
UE 811/2013 performance in average ambient conditions (average) - 55 °C - Pdesignh ≤ 70 kW (2)					
Pdesignh	kW	5	5	7	8
SCOP	W/W	3,28	3,26	3,30	3,25
ηsh	%	128,10	127,40	129,00	127,00
Efficiency energy class		A++	A++	A++	A++
Performance as combined heat generator					
Bleeding profile		L	L	L	L
Efficiency energy class		A	A	A	A

(1) Efficiencies for low temperature applications (35 °C)

(2) Efficiencies for average temperature applications (55 °C)

Indoor unit		BHP060F	BHP060F	BHP100F	BHP100F
Outdoor unit		BHP040	BHP060	BHP080	BHP100
Cooling capacity with low leaving water temp (UE n° 2016/2281)					
SEER	W/W	4,21	4,12	4,11	4,12
η_{sc}	%	165,00	162,00	161,00	162,00

INDOOR UNIT

BHP_W indoor wall unit

		BHP060W	BHP100W	BHP160W
Electric data				
Rated power input (1)	kW	3,10	6,10	6,10
Electric heater				
Number	no.	2	2	2
Power of the single heater	kW	1,50	3,00	3,00
System side heat exchanger				
Type	type		Brazed plate	
Number	no.	1	1	1
Unit / system input	type		G1 male	
Unit / system output	type		G1 male	
DHW output	type		G1 male	
Circulator				
Quantity	no.	1	1	1
Motor	type		DC brushless	
Expansion vessel				
Number	no.	1	1	1
Volume	l	10,0	10,0	10,0
Maximum pressure	bar	2,5	2,5	2,5
Sound data calculated in cooling mode (2)				
Sound power level	dB(A)	42,0	42,0	42,0
Sound pressure level	dB(A)	14,0	14,0	14,0
Power supply				
Power supply			230V ~ 50Hz	

(1) The rated power input (rated current input) is the maximum input electrical power (maximum current input) from the system, in accordance with the Standards EN 60335-1 and EN 60335-2-40.

(2) Sound power calculated on the basis of measurements made in accordance with UNI EN ISO 9614-2, as required for Eurovent certification. Sound pressure (cold functioning) measured in free field, 10m away from the unit external surface (in compliance with UNI EN ISO 3744).

Three-phase wall unit BHP_WT

		BHP100WT	BHP160WT
Electric data			
Rated power input (1)	kW	6,10	6,10
Electric heater			
Number	no.	2	2
Power of the single heater	kW	3,00	3,00
System side heat exchanger			
Type	type		Brazed plate
Number	no.	1	1
Unit / system input	type		G1 male
Unit / system output	type		G1 male
DHW output	type		G1 male
Circulator			
Quantity	no.	1	1
Motor	type		DC brushless
Expansion vessel			
Number	no.	1	1
Volume	l	10,0	10,0
Maximum pressure	bar	2,5	2,5
Sound data calculated in cooling mode (2)			
Sound power level	dB(A)	42,0	42,0
Sound pressure level	dB(A)	14,0	14,0
Power supply			
Power supply			400V ~ 3N 50Hz

(1) The rated power input (rated current input) is the maximum input electrical power (maximum current input) from the system, in accordance with the Standards EN 60335-1 and EN 60335-2-40.

(2) Sound power calculated on the basis of measurements made in accordance with UNI EN ISO 9614-2, as required for Eurovent certification. Sound pressure (cold functioning) measured in free field, 10m away from the unit external surface (in compliance with UNI EN ISO 3744).

BHP_F indoor base unit

		BHP060F	BHP100F
Electric data			
Rated power input (1)	kW	3,10	6,10
Electric heater			
Number	no.	2	2
Power of the single heater	kW	1,50	3,00
System side heat exchanger			
Type	type	Braze plate	
Number	no.	1	1
Unit / system input	type	G1 male	
Mains water input	type	G1 male	
Unit / system output	type	G1 male	
DHW output	type	G1 male	
Circulator			
Quantity	no.	1	1
Motor	type	DC brushless	
Expansion vessel			
Number	no.	1	1
Volume	l	10,0	10,0
Maximum pressure	bar	2,5	2,5
Storage tank (DHW)			
Volume	l	185	185
Sound data calculated in cooling mode (2)			
Sound power level	dB(A)	42,0	42,0
Sound pressure level	dB(A)	14,0	14,0
Power supply			
Power supply		230V ~ 50Hz	

(1) The rated power input (rated current input) is the maximum input electrical power (maximum current input) from the system, in accordance with the Standards EN 60335-1 and EN 60335-2-40.

(2) Sound power calculated on the basis of measurements made in accordance with UNI EN ISO 9614-2, as required for Eurovent certification. Sound pressure (cold functioning) measured in free field, 10m away from the unit external surface (in compliance with UNI EN ISO 3744).

OUTDOOR UNIT

		BHP040	BHP060	BHP080	BHP080T	BHP100	BHP100T
Electric data							
Rated current input (1)	A	10,0	10,0	19,0	7,5	22,0	7,5
Compressor							
Type	type	Rotativo doppio stadio inverter					
Number	no.	1	1	1	1	1	1
Circuits	no.	1	1	1	1	1	1
Refrigerant	type	R32					
Refrigerant charge	kg	1,00	1,00	1,60	1,84	1,60	1,84
Potential global heating	GWP	675kgCO ₂ eq					
Oil							
Type	type	FW68DA					
Quantity	l	0,47	0,47	0,84	0,84	0,84	0,84
Refrigeration pipework							
Diameter of liquid refrigerant connections	mm (inch)	6,35 (1/4")					
Diameter of refrigerant gas connections	mm (inch)	12,7 (1/2")					
Exchanger							
Type	type	Finned coil					
Louvers type	type	Golden fin					
Number	no.	1	1	1	1	1	1
Expansion vessel							
Type	type	Electronic expansion valve					
Number	no.	1	1	1	1	1	1
Fan							
Type	type	Inverter axial					
Fan motor	type	DC brushless					
Number	no.	1	1	1	1	1	1
Air flow rate	m ³ /h	3200	3200	3300	3300	3300	3300
Sound data calculated in cooling mode (2)							
Sound power level	dB(A)	62,0	62,0	67,0	68,0	68,0	68,0
Sound pressure level (1 m)	dB(A)	52,0	52,0	55,0	55,0	55,0	55,0
Sound pressure level (10 m)	dB(A)	34,0	34,0	39,0	40,0	40,0	40,0
Power supply							
Power supply		230V ~ 50Hz		400V 3N ~ 50Hz		230V ~ 50Hz	400V 3N ~ 50Hz
		BHP120	BHP120T	BHP140	BHP140T	BHP160	BHP160T
Electric data							
Rated current input (1)	A	25,6	9,2	28,7	11,5	30,3	11,5
Compressor							
Type	type	Rotativo doppio stadio inverter					
Number	no.	1	1	1	1	1	1
Circuits	no.	1	1	1	1	1	1
Refrigerant	type	R32					
Refrigerant charge	kg	1,84	1,84	1,84	1,84	1,84	1,84
Potential global heating	GWP	675kgCO ₂ eq					
Oil							
Type	type	FW68DA					
Quantity	l	1,05	1,05	1,05	1,05	1,05	1,05
Refrigeration pipework							
Diameter of liquid refrigerant connections	mm (inch)	6,35 (1/4")					
Diameter of refrigerant gas connections	mm (inch)	12,7 (1/2")		15,87 (5/8")			
Exchanger							
Type	type	Finned coil					
Louvers type	type	Golden fin					
Number	no.	1	1	1	1	1	1
Expansion vessel							
Type	type	Electronic expansion valve					
Number	no.	1	1	1	1	1	1
Fan							
Type	type	Inverter axial					
Fan motor	type	DC brushless					
Number	no.	1	1	1	1	1	1
Air flow rate	m ³ /h	5044	5044	5044	5044	5044	5044
Sound data calculated in cooling mode (2)							
Sound power level	dB(A)	68,0	68,0	68,0	68,0	68,0	68,0
Sound pressure level (1 m)	dB(A)	60,0	60,0	61,0	61,0	61,0	61,0
Sound pressure level (10 m)	dB(A)	40,0	40,0	40,0	40,0	40,0	40,0
Power supply							
Power supply		230V ~ 50Hz	400V 3N ~ 50Hz	230V ~ 50Hz	400V 3N ~ 50Hz	230V ~ 50Hz	400V 3N ~ 50Hz

(1) The rated power input (rated current input) is the maximum input electrical power (maximum current input) from the system, in accordance with the Standards EN 60335-1 and EN 60335-2-40.

(2) Sound power calculated on the basis of measurements made in accordance with UNI EN ISO 9614-2, as required for Eurovent certification. Sound pressure (cold functioning) measured in free field, 10m away from the unit external surface (in compliance with UNI EN ISO 3744).

DIMENSIONS AND WEIGHTS

Indoor units

BHP_F

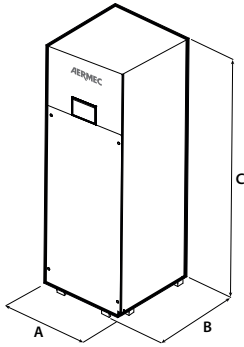

BHP_W

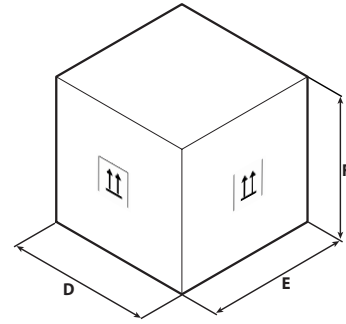
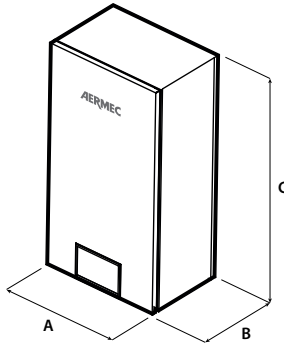

Carton Box Example

BHP_W

		BHP060W	BHP100W	BHP160W
Indoor unit				
A	mm	460	460	460
B	mm	318	318	318
C	mm	860	860	860
D	mm	568	568	568
E	mm	390	390	390
F	mm	1133	1133	1133
Net weight	kg	62,0	62,0	58,0
Weight for transport	kg	71,0	71,0	71,0

BHP_WT

		BHP100WT	BHP160WT
Indoor unit			
A	mm	460	460
B	mm	318	318
C	mm	860	860
D	mm	568	568
E	mm	390	390
F	mm	1133	1133
Net weight	kg	60,0	60,0
Weight for transport	kg	71,0	71,0

BHP_F

		BHP060F	BHP100F
Indoor unit			
A	mm	600	600
B	mm	600	600
C	mm	1756	1756
D	mm	803	803
E	mm	683	683
F	mm	2000	2000
Net weight	kg	210,0	210,0
Weight for transport	kg	233,0	233,0

Outdoor units

BHP

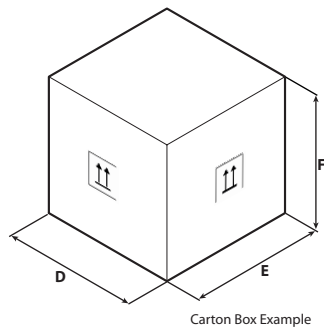
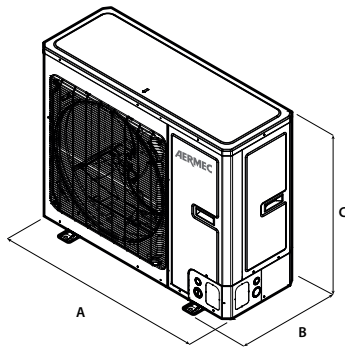

Carton Box Example

BHP

		BHP040	BHP060	BHP080	BHP080T	BHP100	BHP100T
Outdoor unit							
A	mm	975	975	982	982	982	982
B	mm	396	396	427	360	427	360
C	mm	702	702	787	787	787	787
D	mm	1028	1028	1097	1097	1097	1097
E	mm	458	458	478	478	478	478
F	mm	830	830	937	937	937	937
Net weight	kg	55,0	55,0	82,0	88,0	82,0	88,0
Weight for transport	kg	65,0	65,0	92,0	98,0	92,0	98,0
BHP120 BHP120T BHP140 BHP140T BHP160 BHP160T							
Outdoor unit							
A	mm	940	940	940	940	940	940
B	mm	460	460	460	460	460	460
C	mm	820	820	820	820	820	820
D	mm	1103	1103	1103	1103	1103	1103
E	mm	573	573	573	573	573	573
F	mm	973	973	973	973	973	973
Net weight	kg	104,0	110,0	104,0	110,0	104,0	110,0
Weight for transport	kg	114,0	121,0	114,0	121,0	114,0	121,0

Aermec reserves the right to make any modifications deemed necessary.
All data is subject to change without notice. Aermec does not assume responsibility or liability for errors or omissions.

Aermec S.p.A.
Via Roma, 996 - 37040 Bevilacqua (VR) - Italia
Tel. 0442633111 - Telefax 044293577
www.aermec.com