

CL 025H-200H

Reversible air/water heat pump

Cooling capacity 6,5 ÷ 50,9 kW – Heating capacity 7,7 ÷ 44,8 kW



- Cooling / heating / high-temperature water production even for DHW production.
- Water produced up to 60 °C
- Heating operations with external temperatures down to -15 °C
- Fan Plug-fan



DESCRIPTION

Reversible air/water heat pump for air conditioning systems with cold water production for cooling rooms and hot water for heating and/or domestic hot water services, suitable for connection with small or medium users. The base, the structure and the panels are made of galvanized steel treated with polyester paint RAL 9003.

VERSIONS

- ° Standard
- A With storage tank and pump
- P With pump

FEATURES

Operating field

Working at full load up to -15 °C outside air temperature in winter, and up to 46 °C in summer. Hot water production up to 60 °C.

EC fan plug-fan

The units are equipped with plug-fans and inverter motors coupled directly with the fan, with the electronic condensation control as standard, which adjusts the air flow according to the actual system requirements, with benefits in terms of consumption and noise reduction.

In addition, compared to conventional centrifugal fans, they do not feature belt and pulley transmission, resulting in easy flow adjustment, compactness, versatility, easy maintenance and no vibrations.

Air supply

Horizontal or vertical, adjustable during installation for all sizes.

Directional air discharge hood:

- plastic for sizes 050 to 090
- galvanised steel for the other sizes

Version with Integrated hydronic kit

Integrated hydronic kit containing the main hydraulic components; available with various configurations to obtain a solution that allows you to save money and to facilitate installation.

Hot water production

Special attention has been paid to winter operation: compared with traditional heat pumps, the operating limits have been extended thanks to particular technological expedients.

MODUCONTROL CONTROL

The command panel of the unit allows the rapid setting of the working parameters of the machine, and their visualisation. The display consists of 4 figures and various LEDs for indicating the type of operational mode, the visualisation of the parameters set and of any alarms triggered. The card stores all the default settings and any modifications.

The regulation using an outside air temperature sensor allows a dynamic control of the water temperature produced by increasing the energy efficiency of the system.

ACCESSORIES

AERBAC-MODU: Ethernet communication Interface for protocols Bacnet/IP, Modbus TCP/IP, SNMP. The accessory is supplied with the unit and must be installed on an external electrical panel.

AERLINK: Wifi Gateway with an RS485 serial port that can be installed on all machines or on all controllers having an RS485 serial port themselves. The module is capable of simultaneously activating the AP WIFI (Access point) and WIFI Station functions, the latter making it possible to connect to the home or business LAN both with VMF-E5 and E6. To facilitate certain management and control operations of the unit, the AERAPP and AERPLANTS applications are available both for Android and iOS systems.

AERSET: It makes it possible to automatically compensate for the operation setting of the unit to which it is connected, based on a 0-10V MODBUS input signal. Mandatory accessory MODU-485BL.

MODU-485BL: RS-485 interface for supervision systems with MODBUS protocol.

MULTICONTROL: Allows the simultaneous control of several units (up to 4), installed in the same hydraulic system.

PR3: Simplified remote panel. This makes it possible to carry out the unit's basic controls with the signalling of alarms. Can be made remote with shielded cable up to 150 m.

SDHW: Domestic hot water sensor. To be used with a storage tank for the control of water temperature produced.

SGD: Electronic expansion that enables connecting to the photovoltaic system and heat pumps to accumulate heat in the DHW tank or in the heating system during the photovoltaic production phase and release it at times when heating demand is highest.

SPLW: System water temperature sensor. In most cases the loose supplied sensors for each chiller/heat pump are sufficient. In cases of a common flow/return header this sensor can be used to control the common system supply water temperature for the chillers connected to the header, or it can be used for temperature monitoring

VT: Anti-vibration supports.

BSKW: Electric heaters kit with IP44 panel for remote mounting in a sheltered area.

CLPA: Galvanised steel plenum to be installed on the condenser coil, facilitates duct installations.

FACTORY FITTED ACCESSORIES

DRE: Electronic device for peak current reduction.

KRB: Electric anti-freeze resistance kit for base.

GPCL: Protection grille for the source side exchange coil.

COMPATIBILITY WITH VMF SYSTEM

For more information about VMF system, refer to the dedicated documentation.

ACCESSORIES COMPATIBILITY

Accessories

Model	Ver	025	030	040	050	070	080	090	100	150	200
AERBAC-MODU	°A,P	*	*	*	*	*	*	*	*	*	*
AERLINK	°A,P	*	*	*	*	*	*	*	*	*	*
AERSET	°A,P	*	*	*	*	*	*	*	*	*	*
MODU-485BL	°A,P	*	*	*	*	*	*	*	*	*	*
MULTICONTROL	°A,P	*	*	*	*	*	*	*	*	*	*
PR3	°A,P	*	*	*	*	*	*	*	*	*	*
SDHW (1)	°A,P	*	*	*	*	*	*	*	*	*	*
SGD	°A,P	*	*	*	*	*	*	*	*	*	*
SPLW (2)	°A,P	*	*	*	*	*	*	*	*	*	*

(1) Probe required for MULTICONTROL for managing the domestic hot water system.

(2) Probe required for MULTICONTROL to manage the secondary circuit system.

■ MODU-485BL = Accessory mandatory for the production of domestic hot water

Antivibration

Ver	025	030	040	050	070	080	090	100	150	200
°P	VT9	VT9	VT9	VT9	VT9	VT9	VT9	VT15	VT15	VT15
A	VT15A	VT15A	VT15A	VT15A	VT15A	VT15A	VT15A	VT15	VT15	VT15

BSKW: Electric heater kit

Ver	025	030	040	050	070	080	090	100	150	200
Power supply: °										
°A,P	BS6KW400T, BS9KW400T	BS6KW400T, BS9KW400T	BS6KW400T, BS9KW400T	BS6KW400T, BS9KW400T	BS6KW400T, BS9KW400T	BS6KW400T, BS9KW400T	BS6KW400T, BS9KW400T	BS6KW400T, BS9KW400T	BS6KW400T, BS9KW400T	BS6KW400T, BS9KW400T
Power supply: M										
°A,P	BS4KW230M, BS6KW230M	BS4KW230M, BS6KW230M	BS4KW230M, BS6KW230M	-	-	-	-	-	-	-

Galvanised steel plenum

Ver	025	030	040	050	070	080	090	100	150	200
°A,P	CLPA1 (1)	CLPA1 (1)	CLPA2 (2)	CLPA2 (2)	CLPA2 (2)	CLPA2 (2)	CLPA2 (2)	CLPA3	CLPA3	CLPA3

(1) Not compatible with the GPCL1 accessory

(2) Not compatible with the GPCL2 accessory

Device for peak current reduction

Ver	025	030	040	050	070	080	090	100	150	200
Power supply: °										
°A,P	DRES (1)	DRES (1)	DRES (1)	DRES (1)	DRES (1)	DRES (1)	DRES (1)	DRES x 2 (1)	DRES x 2 (1)	DRES x 2 (1)

(1) Only for supplies of 400V 3N ~ 50Hz and 400V 3 ~ 50Hz. x 2 or x 3 (if present) indicates the quantity to be ordered.

A grey background indicates the accessory must be assembled in the factory

Electric Heater for the Base

Ver	025	030	040	050	070	080	090	100	150	200
°A,P	KRB4 (1)	KRB4 (1)	KRB5 (1)	KRB5 (1)	KRB5 (1)	KRB5 (1)	KRB5 (1)	KRB6 (1)	KRB6 (1)	KRB6 (1)

(1) Incompatible with the condensate collection basin accessory with integrated resistance.

A grey background indicates the accessory must be assembled in the factory

Anti-intrusion grid

Ver	025	030	040	050	070	080	090	100	150	200
°A,P	GPCL1	GPCL1	GPCL2	GPCL2	GPCL2	GPCL2	GPCL2	GPCL3	GPCL3	GPCL3

A grey background indicates the accessory must be assembled in the factory

CONFIGURATOR

Field	Description
1,2	CL
3,4,5	Size 025, 030, 040, 050, 070, 080, 090, 100, 150, 200
6	Model
H	Heat pump
7	Execution
°	Standard
8	Version
°	Standard
A	With storage tank and pump (1)
P	With pump
9	Heat recovery
°	Without heat recovery
10	Coils
°	Copper-aluminium
R	Copper pipes-copper fins
S	Copper pipes-Tinned copper fins
V	Copper pipes-Coated aluminium fins
11	Operating field
°	Standard mechanic thermostatic valve (2)
Y	Low temperature mechanic thermostatic valve (3)
Z	Low temperature electronic thermostatic valve (4)
12	Evaporator
°	Standard
13	Power supply
°	400V 3N ~ 50Hz (5)
M	230V ~ 50Hz (6)

(1) The version with integrated storage tank is not suitable for the production of domestic hot water (DHW).

(2) Water produced from 4 °C ÷ 18 °C
(3) Water produced from 0 °C ÷ -10 °C

(4) Water produced from 0 °C ÷ 4 °C
(5) Only for CL 025 ÷ 200 sizes
(6) Only for CL 025 ÷ 040 sizes

PERFORMANCE SPECIFICATIONS 12 °C / 7 °C - 40 °C / 45 °C

CL - (H°) - (400V 3N ~ 50Hz / 230V ~ 50Hz)

Size		025	030	040	050	070	080	090	100	150	200
Cooling performance 12 °C / 7 °C (1)											
Cooling capacity	kW	6,4	8,4	10,4	11,9	14,0	15,5	19,0	23,9	31,3	37,6
Input power	kW	2,6	3,1	3,8	4,2	4,8	5,6	6,8	8,2	10,9	14,4
Cooling total input current - 400V	A	5,5	6,3	6,6	7,5	8,3	9,6	13,0	14,0	21,0	26,0
Cooling total input current - 230V	A	13,0	15,0	16,0	-	-	-	-	-	-	-
EER	W/W	2,44	2,73	2,74	2,87	2,90	2,77	2,81	2,93	2,86	2,61
Water flow rate system side	l/h	1104	1441	1785	2054	2411	2676	3272	4122	5388	6477
Pressure drop system side	kPa	13	12	13	11	15	26	26	34	22	43
Heating performance 40 °C / 45 °C (2)											
Heating capacity	kW	7,9	9,8	12,5	14,4	15,9	18,6	21,0	27,8	34,8	43,8
Input power	kW	2,3	2,9	3,7	4,1	4,7	5,5	6,5	8,1	10,6	14,4
Heating total input current - 400V	A	5,5	6,2	6,4	7,5	8,1	9,2	13,0	14,0	19,0	26,0
Heating total input current - 230V	A	12,0	14,0	15,0	-	-	-	-	-	-	-
COP	W/W	3,41	3,32	3,40	3,52	3,36	3,40	3,20	3,44	3,27	3,03
Water flow rate system side	l/h	1368	1693	2164	2502	2756	3214	3634	4822	6034	7581
Pressure drop system side	kPa	19	16	18	17	21	32	34	49	30	42

(1) Data EN 14511:2022; Heat exchanger water (services side) 12 °C / 7 °C; outside air 35 °C

(2) Data EN 14511:2022; System side water heat exchanger 40 °C / 45 °C; Outside air 7 °C d.b. / 6 °C w.b.

CL - (HP/HA) - (400V 3N ~ 50Hz / 230V ~ 50Hz)

Size		025	030	040	050	070	080	090	100	150	200
Cooling performance 12 °C / 7 °C (1)											
Cooling capacity	kW	6,5	8,4	10,5	12,0	14,1	15,7	19,1	24,2	31,6	38,0
Input power	kW	2,6	3,0	3,7	4,2	4,8	5,6	6,7	8,3	11,3	14,7
Cooling total input current - 400V	A	5,8	6,7	7,0	8,1	8,9	10,0	14,0	15,0	23,0	28,0
Cooling total input current - 230V	A	13,0	16,0	16,0	-	-	-	-	-	-	-
EER	W/W	2,49	2,79	2,79	2,90	2,94	2,82	2,85	2,91	2,81	2,58
Water flow rate system side	l/h	1104	1441	1785	2054	2411	2676	3272	4122	5388	6477
Useful head system side	kPa	76	75	69	92	86	80	64	99	158	145
Heating performance 40 °C / 45 °C (2)											
Heating capacity	kW	7,8	9,7	12,4	14,3	15,8	18,4	20,8	27,6	34,5	43,4
Input power	kW	2,3	2,9	3,6	4,1	4,7	5,4	6,5	8,2	11,0	14,8
Heating total input current - 400V	A	5,9	6,6	6,8	8,1	8,7	9,9	13,0	15,0	21,0	28,0
Heating total input current - 230V	A	12,0	15,0	16,0	-	-	-	-	-	-	-
COP	W/W	3,42	3,34	3,42	3,50	3,35	3,40	3,21	3,35	3,14	2,92
Water flow rate system side	l/h	1368	1693	2164	2502	2756	3214	3634	4822	6034	7581
Useful head system side	kPa	68	67	56	84	78	66	53	72	133	103

(1) Data EN 14511:2022; Heat exchanger water (services side) 12°C / 7°C; outside air 35°C
 (2) Data EN 14511:2022; System side water heat exchanger 40 °C / 45 °C; Outside air 7 °C d.b. / 6 °C w.b.

PERFORMANCE SPECIFICATIONS 23 °C / 18 °C - 30 °C / 35 °C

CL - (H°) - (400V 3N ~ 50Hz / 230V ~ 50Hz)

Size		025	030	040	050	070	080	090	100	150	200
Cooling performance 23 °C / 18 °C (1)											
Cooling capacity	kW	8,5	11,1	13,8	15,8	18,6	20,6	25,2	31,7	41,6	49,9
Input power	kW	2,8	3,3	4,0	4,4	5,1	6,0	7,2	8,7	11,6	15,4
Cooling total input current - 400V	A	5,8	6,6	6,9	8,0	8,7	10,0	14,0	15,0	22,0	27,0
Cooling total input current - 230V	A	13,0	16,0	17,0	-	-	-	-	-	-	-
EER	W/W	3,05	3,42	3,43	3,59	3,63	3,45	3,50	3,63	3,57	3,24
Water flow rate system side	l/h	1472	1922	2381	2740	3216	3570	4364	5498	7187	8639
Pressure drop system side	kPa	23	21	23	20	27	46	46	60	39	77
Heating performance 30 °C / 35 °C (2)											
Heating capacity	kW	8,2	10,1	12,9	15,0	16,5	19,2	21,7	28,9	36,1	45,4
Input power	kW	2,0	2,5	3,1	3,5	4,0	4,6	5,5	6,8	9,0	12,4
Heating total input current - 400V	A	4,7	5,3	5,4	6,4	6,8	7,8	11,0	12,0	16,0	22,0
Heating total input current - 230V	A	10,0	12,0	13,0	-	-	-	-	-	-	-
COP	W/W	4,16	4,08	4,15	4,30	4,12	4,17	3,93	4,22	3,99	3,67
Water flow rate system side	l/h	1413	1749	2235	2585	2846	3320	3754	4981	6233	7832
Pressure drop system side	kPa	20	17	19	18	22	34	36	52	32	45

(1) Data EN 14511:2022; System side water heat exchanger 23 °C / 18 °C; External air 35 °C
 (2) Data EN 14511:2022; System side water heat exchanger 30 °C / 35 °C; External air 7 °C d.b. / 6 °C w.b.

CL - (HP/HA) - (400V 3N ~ 50Hz / 230V ~ 50Hz)

Size		025	030	040	050	070	080	090	100	150	200
Cooling performance 23 °C / 18 °C (1)											
Cooling capacity	kW	8,6	11,2	13,9	16,0	18,7	20,8	25,4	32,0	41,9	50,3
Input power	kW	2,7	3,2	4,0	4,4	5,1	5,9	7,2	8,9	12,1	15,8
Cooling total input current - 400V	A	6,2	7,0	7,3	8,6	9,4	11,0	15,0	16,0	24,0	30,0
Cooling total input current - 230V	A	14,0	17,0	17,0	-	-	-	-	-	-	-
EER	W/W	3,13	3,50	3,50	3,64	3,69	3,52	3,55	3,58	3,45	3,18
Water flow rate system side	l/h	1472	1922	2381	2740	3216	3570	4364	5498	7187	8639
Useful head system side	kPa	63	59	48	79	66	55	27	41	81	57
Heating performance 30 °C / 35 °C (2)											
Heating capacity	kW	8,1	10,0	12,8	14,8	16,3	19,1	21,6	28,6	35,8	45,0
Input power	kW	1,9	2,4	3,1	3,4	4,0	4,6	5,5	7,0	9,4	12,8
Heating total input current - 400V	A	5,0	5,6	5,8	7,0	7,5	8,5	11,0	13,0	18,0	24,0
Heating total input current - 230V	A	11,0	13,0	14,0	-	-	-	-	-	-	-
COP	W/W	4,18	4,11	4,19	4,30	4,13	4,19	3,94	4,09	3,80	3,52
Water flow rate system side	l/h	1413	1749	2235	2585	2846	3320	3754	4981	6233	7832
Useful head system side	kPa	66	65	54	82	76	63	49	65	124	93

(1) Data EN 14511:2022; System side water heat exchanger 23 °C / 18 °C; External air 35 °C
 (2) Data EN 14511:2022; System side water heat exchanger 30 °C / 35 °C; External air 7 °C d.b. / 6 °C w.b.

ENERGY DATA

Size			025	030	040	050	070	080	090	100	150	200
Cooling capacity with low leaving water temp (UE n° 2016/2281)												
SEER	°	W/W	2,93	3,27	3,32	3,45	3,43	3,27	3,39	4,06	4,06	3,66
	A,P	W/W	3,11	3,47	3,53	3,62	3,62	3,46	3,60	4,06	3,85	3,60
ηsc	°	%	114,20	127,60	129,60	134,80	134,00	127,80	132,40	159,20	159,20	143,40
	A,P	%	121,40	135,90	138,00	142,00	141,70	135,30	141,00	159,50	150,80	141,10
UE 811/2013 performance in average ambient conditions (average) - 35 °C - Pdesignh ≤ 70 kW (1)												
Pdesignh	°	kW	-	-	-	-	-	-	-	-	-	-
	A,P	W/W	3,35	3,35	3,45	3,58	3,45	3,53	3,30	3,53	3,35	3,23
SCOP	°	W/W	3,43	3,43	3,53	3,63	3,50	3,58	3,35	3,45	3,23	3,20
	A,P	W/W	3,43	3,43	3,53	3,63	3,50	3,58	3,35	3,45	3,23	3,20
ηsh	°	%	131,00	131,00	135,00	140,00	135,00	138,00	129,00	138,00	131,00	126,00
	A,P	%	134,00	134,00	138,00	142,00	137,00	140,00	131,00	135,00	126,00	125,00
Efficiency energy class	°	A,P	A+	A+	A+	A+	A+	A+	A+	A+	A+	A+

(1) Efficiencies for low temperature applications (35 °C)

ELECTRIC DATA

Size			025	030	040	050	070	080	090	100	150	200
Power supply: °												
Electric data												
Maximum current (FLA)	°	A	11,0	11,9	11,9	13,5	14,7	15,2	20,4	27,0	30,3	40,8
	A,P	A	11,4	12,4	12,3	14,3	15,4	15,9	21,1	29,0	33,4	43,8
Peak current (LRA)	°	A	44,6	44,6	57,1	64,2	74,2	94,2	105,2	77,7	109,3	125,6
	A,P	A	45,0	45,0	57,6	64,9	74,9	94,9	105,9	79,6	112,4	128,6
Power supply: M												
Electric data												
Maximum current (FLA)	°	A	19,0	24,0	24,0	-	-	-	-	-	-	-
	A,P	A	19,8	24,7	25,0	-	-	-	-	-	-	-
Peak current (LRA)	°	A	86,0	96,0	96,0	-	-	-	-	-	-	-
	A,P	A	87,1	96,5	97,1	-	-	-	-	-	-	-

GENERAL TECHNICAL DATA

Size			025	030	040	050	070	080	090	100	150	200	
Compressor													
Type	°	A,P	type		Scroll								
Compressor regulation	°	A,P	Type		On-off								
Number	°	A,P	no.	1	1	1	1	1	1	2	2	2	
Circuits	°	A,P	no.	1	1	1	1	1	1	1	1	1	
Refrigerant	°	A,P	type		R410A								
Refrigerant charge (1)	°	A,P	kg	2,7	2,7	4,3	5,6	5,6	5,6	5,7	8,3	8,0	7,5
System side heat exchanger													
Type	°	A,P	type		Brazen plate								
Number	°	A,P	no.	1	1	1	1	1	1	1	1	1	
Hydraulic connections													
Connections (in/out)	°	A,P	Type		Gas - F								
Size (in)	°	A,P	Ø		1¼								
Size (out)	°	A,P	Ø		1¼								
Fan													
Type	°	A,P	type		Plug-fan								
Fan motor	°	A,P	type		Inverter								
Number	°	A,P	no.	1	1	1	1	1	1	2	2	2	
Air flow rate	°	A,P	m³/h	4000	4000	6500	6500	6500	6500	7500	10000	12000	16000
High static pressure	°	A,P	Pa	50	50	50	80	80	80	80	100	100	
Intake plus machine body													
Sound power level	°	A,P	dB(A)	78,0	78,0	73,0	73,0	73,0	73,0	76,0	74,0	79,0	80,0
Sound pressure level in cooling mode (10 m)	°	A,P	dB(A)	46,0	46,0	41,0	41,0	41,0	41,0	44,0	42,0	47,0	48,0
Machine exhaust													
Sound power level	°	A,P	dB(A)	78,0	78,0	78,0	78,0	78,0	78,0	81,0	78,0	83,0	85,0
Sound pressure level in cooling mode (10 m)	°	A,P	dB(A)	46,0	46,0	46,0	46,0	46,0	49,0	47,0	52,0	54,0	

(1) The load indicated in the table is an estimated and preliminary value. The final value of the refrigerant load is indicated on the unit's technical label. For further information contact the office.

DISCHARGE HOOD POSSIBLE CONFIGURATIONS

CL 025 ÷ 090

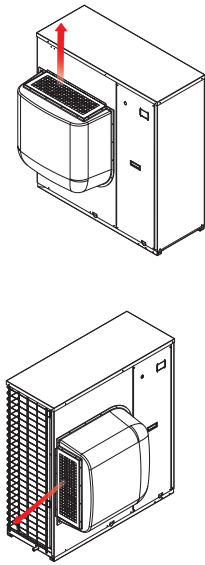

CL 100 ÷ 200

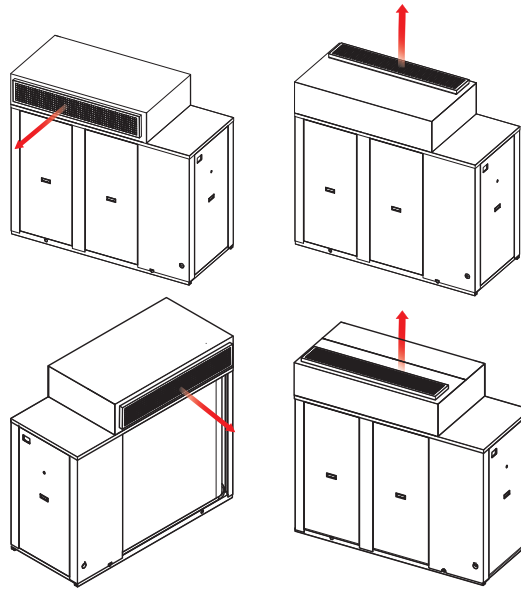

Air supply
Horizontal or vertical, adjustable during installation for all sizes.
Directional air discharge hood:

— plastic for sizes 050 to 090
— galvanised steel for the other sizes

DIMENSIONS

CL 025 ÷ 090

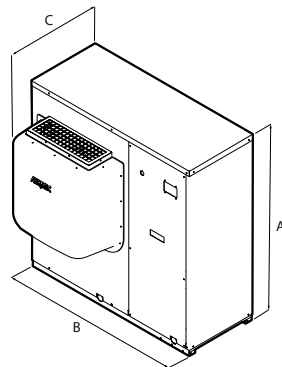

CL 100 ÷ 200

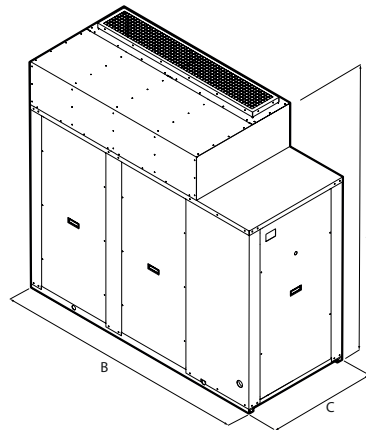

Size			025	030	040	050	070	080	090	100	150	200
Dimensions and weights												
A	°A,P	mm	1028	1028	1281	1281	1281	1281	1281	1674	1674	1674
	°P	mm	1005	1005	1160	1160	1160	1160	1160	1897	1897	1897
B	A	mm	1366	1366	1610	1610	1610	1610	1610	1897	1897	1897
	°A,P	mm	702	702	798	798	798	798	798	801	801	801
C	°	kg	142	142	229	229	240	240	234	504	527	515
	A	kg	172	172	274	274	284	284	279	567	593	581
Empty weight	P	kg	148	148	239	239	250	250	243	517	543	531

Aermec reserves the right to make any modifications deemed necessary.
All data is subject to change without notice. Aermec does not assume responsibility or liability for errors or omissions.

Aermec S.p.A.
Via Roma, 996 - 37040 Bevilacqua (VR) - Italia
Tel. 0442633111 - Telefax 044293577
www.aermec.com