

FCZI

Fan coil for universal and floor installation

Cooling capacity 0,65 ÷ 7,62 kW
Heating capacity 1,45 ÷ 17,02 kW



- Very quiet
- Touch controller mounted on-board. allows remote control with smart devices



DESCRIPTION

fan coil can be installed in any 2/4 pipe system and operates with any heat generator even at low temperatures, and thanks to varied versions and settings, it is easy to pick the ideal solution for any need.

FEATURES

Case

Protective metal cabinet with anti-corrosion polyester RAL 9003 paint, whereas the head with the air distribution grille is in RAL 7047 plastic.

Depending on the version, the distribution grille may be adjustable.

Ventilation group

Centrifugal fans in anti-static plastic material with aerofoil profile designed to achieve high airflows and pressures whilst at the same time producing low noise.

Their characteristics permit energy savings compared to conventional fans. They are statically and dynamically balanced and directly coupled to the motor shaft.

The Brushless electric motor with 0-100% continuous speed variation, which allows precise adaptation to the real demands of the internal environment without temperature fluctuations.

The air flow can be continuously changed through a 1-10 V signal, coming from adjustment and control commands Aermec or from independent adjustment systems.

This lowers noise and generates a better response to heat loads and a higher stability in the desired temperature inside the room.

The high efficiency even with low speed, makes it possible to reduce power consumption (more than 50% less than fan coils with traditional motors).

The plastic augers are extractable for easy and efficient cleaning.

Finned pack heat exchanger

With copper pipes and aluminium louvers, the standard or oversized heat exchanger and the possible secondary heat exchanger have female gas water connections on the left side and the manifolds have air vents.

The coil is not suitable for use in corrosive atmosphere or in environments where aluminium may be subject to corrosion.

Reversibility of the water connections during installation only for units with a standard or boosted main heat exchanger, or standard with BV accessory. Not reversible in all other configurations. In any

case, units with the coil water connections on the right are available at the time of ordering.

Condensate drip

Provided standard in plastic and fixed to the interior structure; with external condensate discharge.

Air filter

Air filter class Coarse 25% for all versions easy to pull out and clean.

Versions

ACT High, with air distribution grille and electronic thermostat

AF High, without built-in command but with front intake

AS Free standing without installed switch

U Universal, with adjustable air distribution grille but without built-in thermostat

UF Universal, with adjustable air distribution grille but without built-in thermostat and with front intake grille

Versions with fixed grille (high cabinet)

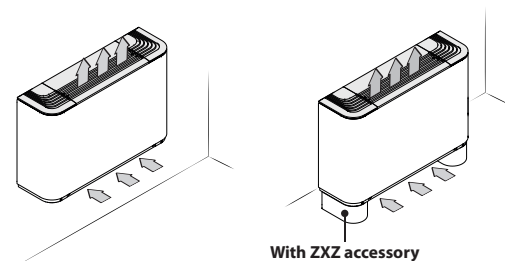

FCZI_AS

- Compatibility with VMF system.
- Without installed switch

FCZI_ACT

- With electronic thermostat for 2-pipe systems only.

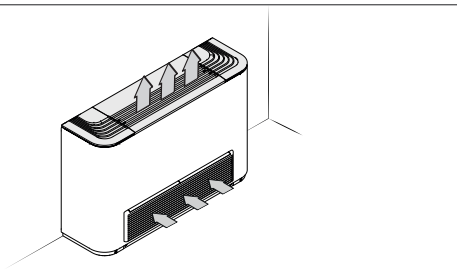

FCZI_AF

- Without installed switch
- Compatibility with VMF system.
- Front intake grille.

Versions with adjustable and fixed grille (universal)

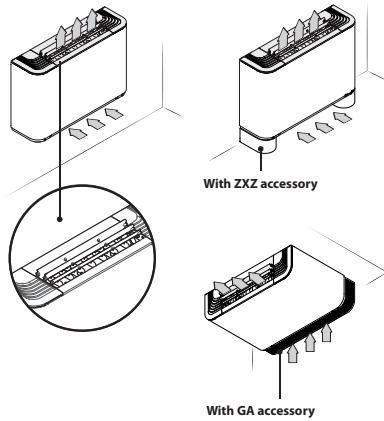

FCZI_U

- Compatibility with VMF system.
- Without installed switch
- Distribution grille with adjustable fins. Sizes 2 and 3 have a single grille, whereas sizes 4, 5, 7 and 9 have three grilles fully independent of each other. When all the louvers have closed, the unit switches off.
- Vertical and horizontal installation for 2-pipe and 4-pipe systems.

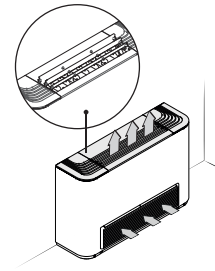

FCZI_UF

- Compatibility with VMF system.
- Without installed switch
- Air delivery grille with adjustable louvers.
- Vertical and horizontal installation.

GUIDE TO SELECTING THE POSSIBLE CONFIGURATIONS

Field	Description
1,2,3,4	FCZI
5	Size 2, 3, 4, 5, 7, 9
6	main heat exchanger
0	Standard
5	Oversized
7	Secondary heat exchanger
0	Without coil
1	Standard
2	Oversized
8,9,10	Version
	Only vertical installation.
ACT	High, with air distribution grille and electronic thermostat
AF	High, without built-in command but with front intake
AS	Free standing without installed switch
	Vertical and horizontal installation.
U	Universal, with adjustable air distribution grille but without built-in thermostat
	Universal, with adjustable air distribution grille but without built-in thermostat and with front intake grille
UF	Universal, with adjustable air distribution grille but without built-in thermostat and with front intake grille

SIZE AVAILABLE FOR VERSION

Size	200	201	202	250	300	301	302	350	400	401	402	450
Versions produced (by size)												
Versions available (by size)	AS,ACT,U	•	•	•	•	•	•	•	•	•	•	•
	AF,UF	•	-	-	•	•	-	-	•	•	-	•
	500	501	502	550	700	701	702	750	900	901	950	
Versions produced (by size)												
Versions available (by size)	A,AS,U,UA	•	•	•	•	•	•	•	•	•	•	•
	AF,UF	•	-	-	•	-	-	-	•	-	•	

ACCESSORIES

Control panels

AER503IR: Flush-mounting thermostat with backlit display, capacitive keypad and infrared receiver, for controlling both brushless fan coils and those with an asynchronous motor. In 2-pipe systems, the thermostat can control standard fan coils or those equipped with an electric heater, with air purifying devices (Cold Plasma and germicidal lamp), with radiant plate or with FCZ-D twin delivery (Dualjet). In addition, it can control systems with radiant panels or mixed (fan coil and radiant floor) systems. Being equipped with an infrared receiver, it can, in turn, be controlled by the VMF-IR remote control.

PRO503: Wall box for AER503IR and VMF-E4 thermostats.

SA5: air probe kit (L = 15 m) with probe-locking cable grommet.

SW3: Water probe (L = 2.5 m) for controlling the minimum and maximum and to allow automatic seasonal switching for electronic thermostats fitted with water side changeover.

SW5: water probe kit (L = 15m) with probe-holder connection point, fixing clip and probe-holder from heat exchanger.

T-TOUCH-I: Touch control on board the machine, for controlling fan coils with brushless motors. In 2-pipe systems, it can control standard fan coils or those equipped with an electric heater, with air purifying devices or with FCZI-D twin delivery (Dualjet). In 4-pipe systems, only standard fan coils.

TX: Wall-mounting thermostat for controlling either brushless fan coils or those with asynchronous motors for 2/4 pipe. In 2-pipe systems, the thermostat can control standard fan coils or those equipped with an electric heater, with air purifying devices, radiant plate or FCZ-D twin delivery (Dualjet).

TXBI: On board thermostat for fan coils 2/4 pipes of the FCZI series with brushless motor, complete with water probe and air probe to be positioned in the dedicated housings. The thermostat in 2-pipe systems it can control standard fan coils or those equipped with electrical resistors, with purification devices (Cold Plasma and germicidal lamp) with the radiating plate or with double flow FCZI-D (Dualjet).

AerSuite

The AerSuite application is used to remotely control the DI24 user interface, with VMF-E19/VMF-E19I thermostats, using Smart Devices with iOS and Android operating systems.

This is an application for Smartphones and Tablets with which the user can access and control the system operation remotely.

For more information about the use of the application and the available functions, refer to the respective documentation on the website.



VMF system

DI24: Interfaccia da incasso (scatola 503) con display touch screen da 2,4" da abbinare agli accessori VMF-E19, VMF-E19I. Permette di regolare e monitorare la temperatura all'interno degli ambienti in modo preciso e puntuale; oltre ad accedere ed interagire con le informazioni di funzionamento del proprio impianto, parametri e allarmi, permette di impostare delle fasce orarie. Grazie alla connessione Wi-Fi di cui è dotato, DI24 in abbinamento con la APP AerSuite (disponibile per Android e iOS) può essere comandato anche da remoto. Tutta la programmazione e gran parte delle funzioni vengono effettuate in maniera semplice e intuitiva utilizzando l'APP. Viene fornita con una placca di colore grigio grafite; ma per permettere di personalizzare l'interfaccia in modo che sia perfettamente integrata con lo stile di ogni casa, DI24 è compatibile con le placche delle maggiori marche disponibili in commercio, per saperne di più vi rimandiamo alla nostra documentazione.

VMF-E19I: Thermostat to be secured to the side of the fan coil, fitted as standard with an air probe and a water probe, it controls systems with 2 pipes, 4 pipes, 2 pipes + Cold Plasma, 2 pipes + UV lamps, 2 pipes + Heating element. Equipped with an external contact to be used as a remote ON-OFF at low voltage. By means of 2-wire serial communication, this thermostat allows for the creation of a single fan coil area (1 master + maximum 5

slaves). Compared to the previous model, thanks to a different dip switch configuration, it allows implementing new features: In systems with two pipes and a heating element - the latter can be activated as a complete replacement - allowing you to warm the environment exclusively with this accessory - Dualjet features are available in standard software and can be set via dip switch - Economy contact/presence sensor - Additional water sensor for overall control in 4-pipe systems (with VMF-SW1 accessory) - Serial RS485, ModBus RTU protocol, for centralised control - Possibility of inserting expansion boards for future developments. The VMF-E19 accessory must be therefore used in masters in the presence of multiple zones, or for communication with the chiller/heat pump - Compatibility with the VMF-IO accessory - Compatibility with VMF-LON expansion board. The thermostat is protected by a fuse.

VMF-E2Z: User interface on the fan coil, with two selectors, one for temperature and the other for speed control; to be combined with accessories VMF-E19 and VMF-E19I.

VMF-E3: Wall mounted user interface, to be combined with accessories VMF-E19, VMF-E19I, with grids GLF_N/M and GLL_N, can be controlled with VMF-IR control.

VMF-E4X: A wall-mounted user interface to be combined with VMF-E19, VMF-E19I, VMF-E24 ed VMF-E24I accessories. Featuring an innovative, extremely slim and cost-effective design, it allows running functions via a capacitive touchscreen keyboard with LCD display. You can choose to adjust the environment temperature with a panel-mounted sensor probe (standard), or with the VMF-E19/E19I probe, or through mediated reading. It also enables the activation of an air purifier (Cold Plasma/ UV lamp) and a heating element. Light grey front panel PANTONE COOL GRAY 1C.

VMF-IO: Manage the unit exclusively from a centralized VMF control panel without area control panel.

VMF-IR: User interface compatible with the AER503IR, VMF-E3 thermostat and with all the grids of cassettes equipped with the infrared receiver compatible with the VMF system.

VMF-LON: Expansion allowing the thermostat to interface with BMS systems that use the LON protocol.

VMF-SW: Water probe (L = 2.5m) used if required in place of the standard unit supplied with the VMF-E19 and VMF-E19I thermostats for mounting it upstream of the valve.

VMF-SW1: Additional water probe (L = 2.5m) to be used if required for 4-pipe systems with the VMF-E19 and VMF-E19I thermostats for maximum control in the cold range

VMHI: The VMHI panel can be used as a user interface for VMF-E19/E19I thermostats, GLFxN/M or GLLxN grids, or as an interface for the MZC system. What determines the function to be performed by the user interface is determined by its correct parametrisation and by following the electrical connections between interface and thermostat or interface and plenum.

Water valves

VCZ_X: 3-way valve kit for single-coil fan coil, RH connections, (VCZ_X4R) or LH (VCZ_X4L) for 4-pipe systems. With totally separate "heating" and "cooling" circuits. This kit consists of two 3-way insulated valves and four connections, complete with electrothermal actuators, insulating shells for the valves, and the relative hydraulic couplings. X4L version for fan coils with LH connections, and X4R for fan coils with RH connections. 230V~50Hz power supply.

VCZ: 3-way motorised valve kit for the main coil. The kit is made up of a valve with its insulating shell, actuator and relative hydraulic fittings. It can be installed on fan coils with both right and left connections. If the valve is combined with the BCZ5 or BCZ6 condensate drain pan, to ensure a better housing it is possible to remove the insulating shell.

VCF44 - 45 - for secondary heat exchanger: The 3-way motorised valve kit for the secondary coil heat only. The kit consists of a valve with its insulating shell, actuator and relevant water fittings; it is suitable to be installed on the fan coils with right and left water connections.

VCZD: 2-way motorised valve kit. The kit consists of a valve, an actuator and the relative pipe fittings. It can be installed on fan coils with both right and left connections.

VJP: Control and balancing combination valve for 2 and 4 pipe systems to install outside the unit, supplied without fittings and hydraulic components. The valve, which can guarantee a constant water flow rate in the terminal, within its operating range.

Additional coil

BV: Hot water heat exchanger with 1 row.

Installation accessories

PCZ: Metal panel for the unit rear closing. SPCZ brackets are necessary to fix floor standing fan coils.

GA: Lower intake grille for encapsulated fan coils. Can also be used in wall-mounted or floor installations, the FIKIT accessory is needed only in the case of floor installation.

FIKIT: Metal supports for vertical installation of the GA grille.

DSCZ4: Condensate drainage device.

BCZ: Condensate drip. If the valve is paired with the BCZ5 or BCZ6 condensate drip tray, the insulating shell can be removed to ensure better housing.

AMP: Wall mounting kit

ZXZ: Pair of stylish and structural feet.

ACCESSORIES COMPATIBILITY

Control panels

Model	Ver	200	201	202	250	300	301	302	350	400	401	402	450
AER503IR (1)	AF,UF	*			*	*			*	*			*
	AS,U	*	*	*	*	*	*	*	*	*	*	*	*
PRO503	AF,UF	*			*	*			*	*			*
	AS,U	*	*	*	*	*	*	*	*	*	*	*	*
SA5 (2)	AF,UF	*			*	*			*	*			*
	AS,U	*	*	*	*	*	*	*	*	*	*	*	*
SW3 (2)	AF,UF	*			*	*			*	*			*
	AS,U	*	*	*	*	*	*	*	*	*	*	*	*
SW5 (2)	AF,UF	*			*	*			*	*			*
	AS,U	*	*	*	*	*	*	*	*	*	*	*	*
T-TOUCH-1	AF,UF	*			*	*			*	*			*
	AS,U	*	*	*	*	*	*	*	*	*	*	*	*
TX (3)	AF,UF	*			*	*			*	*			*
	AS,U	*	*	*	*	*	*	*	*	*	*	*	*
TXBI (4)	AF,UF	*			*	*			*	*			*
	AS,U	*	*	*	*	*	*	*	*	*	*	*	*

Model	Ver	500	501	502	550	700	701	702	750	900	901	950
AER503IR (1)	AF,UF	*			*	*			*	*		*
	AS,U	*	*	*	*	*	*	*	*	*	*	*
PRO503	AF,UF	*			*	*			*	*		*
	AS,U	*	*	*	*	*	*	*	*	*	*	*
SA5 (2)	AF,UF	*			*	*			*	*		*
	AS,U	*	*	*	*	*	*	*	*	*	*	*
SW3 (2)	AF,UF	*			*	*			*	*		*
	AS,U	*	*	*	*	*	*	*	*	*	*	*
SW5 (2)	AF,UF	*			*	*			*	*		*
	AS,U	*	*	*	*	*	*	*	*	*	*	*
T-TOUCH-1	AF,UF	*			*	*			*	*		*
	AS,U	*	*	*	*	*	*	*	*	*	*	*
TX (3)	AF,UF	*			*	*			*	*		*
	AS,U	*	*	*	*	*	*	*	*	*	*	*
TXBI (4)	AF,UF	*			*	*			*	*		*
	AS,U	*	*	*	*	*	*	*	*	*	*	*

(1) Wall-mount installation.

(2) Probe for AER503IR-TX thermostats, if fitted.

(3) Wall-mounting. If the unit intake exceeds 0.7A, or several units need to be managed with a single thermostat, board SIT3 and/or SIT5 is required.

(4) Installation on the fan coil.

VMF system

For more information about VMF system, refer to the dedicated documentation.

Model	Ver	200	201	202	250	300	301	302	350	400	401	402	450
DI24	AF,UF	*			*	*			*	*			*
	AS,U	*	*	*	*	*	*	*	*	*	*	*	*
VMF-E19I (1)	AF,UF	*			*	*			*	*			*
	AS,U	*	*	*	*	*	*	*	*	*	*	*	*
VMF-E2Z	AF,UF	*			*	*			*	*			*
	AS,U	*	*	*	*	*	*	*	*	*	*	*	*
VMF-E3	AF,UF	*			*	*			*	*			*
	AS,U	*	*	*	*	*	*	*	*	*	*	*	*
VMF-E4X	AF,UF	*			*	*			*	*			*
	AS,U	*	*	*	*	*	*	*	*	*	*	*	*
VMF-I0	AF,UF	*			*	*			*	*			*
	AS,U	*	*	*	*	*	*	*	*	*	*	*	*
VMF-IR	AF,UF	*			*	*			*	*			*
	AS,U	*	*	*	*	*	*	*	*	*	*	*	*
VMF-LON	AF,UF	*			*	*			*	*			*
	AS,U	*	*	*	*	*	*	*	*	*	*	*	*
VMF-SW	AF,UF	*			*	*			*	*			*
	AS,U	*	*	*	*	*	*	*	*	*	*	*	*
VMF-SW1	AF,UF	*			*	*			*	*			*
	AS,U	*	*	*	*	*	*	*	*	*	*	*	*

Model	Ver	200	201	202	250	300	301	302	350	400	401	402	450
VMHI	AF,UF	*			*	*			*	*			*
	AS,U	*	*	*	*	*	*	*	*	*	*	*	*
Model	Ver	500	501	502	550	700	701	702	750	900	901	950	
DI24	AF,UF	*			*	*			*	*		*	
	AS,U	*	*	*	*	*	*	*	*	*	*	*	
VMF-E19I (1)	AF,UF	*			*	*			*	*		*	
	AS,U	*	*	*	*	*	*	*	*	*	*	*	
VMF-E2Z	AF,UF	*			*	*			*	*		*	
	AS,U	*	*	*	*	*	*	*	*	*	*	*	
VMF-E3	AF,UF	*			*	*			*	*		*	
	AS,U	*	*	*	*	*	*	*	*	*	*	*	
VMF-E4X	AF,UF	*			*	*			*	*		*	
	AS,U	*	*	*	*	*	*	*	*	*	*	*	
VMF-I0	AF,UF	*			*	*			*	*		*	
	AS,U	*	*	*	*	*	*	*	*	*	*	*	
VMF-IR	AF,UF	*			*	*			*	*		*	
	AS,U	*	*	*	*	*	*	*	*	*	*	*	
VMF-LON	AF,UF	*			*	*			*	*		*	
	AS,U	*	*	*	*	*	*	*	*	*	*	*	
VMF-SW	AF,UF	*			*	*			*	*		*	
	AS,U	*	*	*	*	*	*	*	*	*	*	*	
VMF-SW1	AF,UF	*			*	*			*	*		*	
	AS,U	*	*	*	*	*	*	*	*	*	*	*	
VMHI	AF,UF	*			*	*			*	*		*	
	AS,U	*	*	*	*	*	*	*	*	*	*	*	

(1) Mandatory accessory.

Water valves

3 way valve kit

	200	201	202	250	300	301	302	350	400	401	402	450
Main coil	VCZ41	VCZ41	VCZ41	VCZ41	VCZ42	VCZ42	VCZ42	VCZ42	VCZ42	VCZ42	VCZ42	VCZ42
	VCZ4124	VCZ4124	VCZ4124	VCZ4124	VCZ4224	VCZ4224	VCZ4224	VCZ4224	VCZ4224	VCZ4224	VCZ4224	VCZ4224
Secondary coil	-	VCF44	VCF44	-	-	VCF44	VCF44	-	-	VCF44	VCF44	-
	-	VCF4424	VCF4424	-	-	VCF4424	VCF4424	-	-	VCF4424	VCF4424	-
Additional coil "BV"	VCF44	-	-	-	VCF44	-	-	-	VCF44	-	-	-
	VCF4424	-	-	-	VCF4424	-	-	-	VCF4424	-	-	-
	500	501	502	550	700	701	702	750	900	901	950	
Main coil	VCZ42	VCZ42	VCZ42	VCZ42	VCZ42	VCZ42	VCZ42	VCZ42	VCZ43	VCZ43	VCZ43	
	VCZ4224	VCZ4224	VCZ4224	VCZ4224	VCZ4224	VCZ4224	VCZ4224	VCZ4224	VCZ4324	VCZ4324	VCZ4324	
Secondary coil	-	VCF44	VCF44	-	-	VCF44	VCF44	-	-	VCF45	-	
	-	VCF4424	VCF4424	-	-	VCF4424	VCF4424	-	-	VCF4524	-	
Additional coil "BV"	VCF44	-	-	-	VCF44	-	-	-	VCF45	-	-	
	VCF4424	-	-	-	VCF4424	-	-	-	VCF4524	-	-	

VCZ41 - 42 - 43; VCF44 - 45 (230V~50Hz)

VCZ4124 - 4224 - 4324; VCF4424 - 4524 (24V)

2 way valve kit

	200	201	202	250	300	301	302	350	400	401	402	450
Main coil	VCZD1	VCZD1	VCZD1	VCZD1	VCZD2	VCZD2	VCZD2	VCZD2	VCZD2	VCZD2	VCZD2	VCZD2
	VCZD124	VCZD124	VCZD124	VCZD124	VCZD224	VCZD224	VCZD224	VCZD224	VCZD224	VCZD224	VCZD224	VCZD224
Secondary coil	-	VCFD4	VCFD4	-	-	VCFD4	VCFD4	-	-	VCFD4	VCFD4	-
	-	VCFD424	VCFD424	-	-	VCFD424	VCFD424	-	-	VCFD424	VCFD424	-
Additional coil "BV"	VCFD4	-	-	-	VCFD4	-	-	-	VCFD4	-	-	-
	VCFD424	-	-	-	VCFD424	-	-	-	VCFD424	-	-	-
	500	501	502	550	700	701	702	750	900	901	950	
Main coil	VCZD2	VCZD2	VCZD2	VCZD2	VCZD2	VCZD2	VCZD2	VCZD2	VCZD3	VCZD3	VCZD3	
	VCZD224	VCZD224	VCZD224	VCZD224	VCZD224	VCZD224	VCZD224	VCZD224	VCZD324	VCZD324	VCZD324	
Secondary coil	-	VCFD4	VCFD4	-	-	VCFD4	VCFD4	-	-	VCFD4	-	
	-	VCFD424	VCFD424	-	-	VCFD424	VCFD424	-	-	VCFD424	-	
Additional coil "BV"	VCFD4	-	-	-	VCFD4	-	-	-	VCFD4	-	-	
	VCFD424	-	-	-	VCFD424	-	-	-	VCFD424	-	-	

VCZD1 - 2 - 3; VCFD4 (230V~50Hz)

VCZD124 - 224 - 324; VCFD424 (24V)

Valve Kit for 4 pipe systems

Model	Ver	200	201	202	250	300	301	302	350	400	401	402	450
VCZ1X4L (1)	AF,AS,U,UF	*			*								*
VCZ1X4R (1)	AF,AS,U,UF	*			*								*
VCZ2X4L (1)	AF,AS,U,UF					*			*	*			*
VCZ2X4R (1)	AF,AS,U,UF					*			*	*			*

Model	Ver	500	501	502	550	700	701	702	750	900	901	950
VCZ2X4L (1)	AF,U	.			.							
	AS,U			
VCZ2X4R (1)	AF,U	.			.							
	AS,U			
VCZ3X4L (1)	AF,AS,U,UF									.		.
VCZ3X4R (1)	AF,AS,U,UF									.		.

(1) The valves can be combined with the units if there is a control panel for managing them.

Combined Adjustment and Balancing Valve Kit

Model	Ver	200	201	202	250	300	301	302	350	400	401	402	450
VJP060 (1)	ACT,AS,U				
	AF,U				
VJP060M (2)	ACT,AS,U				
	AF,U				
VJP090 (1)	ACT,AS,U								
	AF,U									.			.
VJP090M (2)	ACT,AS,U								
	AF,U									.			.

Model	Ver	500	501	502	550	700	701	702	750	900	901	950
VJP090 (1)	ACT,AS,U							
	AF,U	.			.							
VJP090M (2)	ACT,AS,U							
	AF,U	.			.							
VJP150 (1)	ACT,AS,U				
	AF,U									.		.
VJP150M (2)	ACT,AS,U				
	AF,U									.		.

(1) 230V~50Hz

(2) 24V

(Heating only) additional coil

Model	Ver	200	201	202	250	300	301	302	350	400	401	402	450
BV122 (1)	ACT,AF,AS,U,UF	.											
BV132 (1)	ACT,AF,AS,U,UF					.							
BV142 (1)	ACT,AF,AS,U,UF									.			

Model	Ver	500	501	502	550	700	701	702	750	900	901	950
BV142 (1)	ACT,AF,AS,U,UF	.										
BV162 (1)	ACT,AF,AS,U,UF									.		
BVZ800 (1)	ACT,AS,U					.						

(1) Not available for sizes with oversized main coil.

Installation accessories

Model	Ver	200	201	202	250	300	301	302	350	400	401	402	450
AMP20	U
AMPZ	U

Model	Ver	500	501	502	550	700	701	702	750	900	901	950
AMP20	U
AMPZ	U

Model	Ver	200	201	202	250	300	301	302	350	400	401	402	450
DSCZ4 (1)	ACT,AS,U
	AF,U

Model	Ver	500	501	502	550	700	701	702	750	900	901	950
DSCZ4 (1)	ACT,AS,U
	AF,U

(1) DSCZ4 due to space problems inside the unit, the VCZ1-2-3-4 X4L/R valves cannot be mounted together with the amp/AMPZ accessories, with all the condensate collection trays. With the VMF-E19/E19I thermostats, please contact the head office.

Model	Ver	200	201	202	250	300	301	302	350	400	401	402	450
BCZ4 (1)	ACT,AS,U
	AF,U
BCZ5 (2)	ACT,AS,U
	AF,U

Model	Ver	500	501	502	550	700	701	702	750	900	901	950
BCZ4 (1)	ACT,AS,U
	AF,U
BCZ5 (2)	ACT,AS,U
	AF,U
BCZ6 (2)	ACT,AS,U									.	.	.
	AF,U									.		.

(1) For vertical installation.

(2) For horizontal installation.

Model	Ver	200	201	202	250	300	301	302	350	400	401	402	450
PCZ200	ACT,AS,U								
	AF,UF	.			.								
PCZ300	ACT,AS,U								
	AF,UF					.			.				
PCZ500	ACT,AS,U								
	AF,UF									.			.
Model	Ver	500	501	502	550	700	701	702	750	900	901	950	
PCZ1000	ACT,AS,U									.	.	.	
	AF,UF									.		.	
PCZ500	ACT,AS,U								
	AF,UF	.			.								
PCZ800	ACT,AS,U								
Model	Ver	200	201	202	250	300	301	302	350	400	401	402	450
GA200	AF,UF	.			.								
	AS,U								
GA300	AF,UF								
	AS,U								
GA500	AF,UF									.			.
	AS,U								
Model	Ver	500	501	502	550	700	701	702	750	900	901	950	
GA500	AF,UF	.			.								
	AS,U								
GA800	AF,UF									.		.	
	AS,U					
Model	Ver	200	201	202	250	300	301	302	350	400	401	402	450
FIKIT200	AF,UF	.			.								
	AS,U								
FIKIT300	AF,UF								
	AS,U								
FIKIT500	AF,UF									.			.
	AS,U								
Model	Ver	500	501	502	550	700	701	702	750	900	901	950	
FIKIT500	AF,UF	.			.								
	AS,U								
FIKIT800	AF,UF									.		.	
	AS,U					
Model	Ver	200	201	202	250	300	301	302	350	400	401	402	450
ZXZ	ACT,AS,U
	AF,UF
Model	Ver	500	501	502	550	700	701	702	750	900	901	950	
ZXZ	ACT,AS,U	
	AF,UF	

PERFORMANCE SPECIFICATIONS

Technical data - 2-pipe systems (main coil)

2-pipe

	FCZI200			FCZI250			FCZI300			FCZI350			FCZI400			FCZI450			FCZI500			FCZI550					
	1	2	3	1	2	3	1	2	3	1	2	3	1	2	3	1	2	3	1	2	3	1	2	3			
	L	M	H	L	M	H	L	M	H	L	M	H	L	M	H	L	M	H	L	M	H	L	M	H			
Heating performance 70 °C / 60 °C (1)																											
Heating capacity	kW			2,02	2,95	3,70	2,20	3,18	4,05	3,47	4,46	5,50	3,77	4,92	6,15	4,32	5,74	7,15	4,57	6,29	7,82	5,27	7,31	8,50	5,82	8,34	9,75
Water flow rate system side	l/h			177	258	324	193	278	355	304	391	482	330	431	539	379	503	627	400	551	685	462	641	745	510	731	855
Pressure drop system side	kPa			6	12	18	7	15	23	7	12	18	8	14	20	9	16	24	6	11	16	12	21	28	10	20	26
Heating performance 45 °C / 40 °C (2)																											
Heating capacity	kW			1,00	1,46	1,84	1,09	1,58	2,01	1,72	2,21	2,73	1,87	2,44	3,06	2,14	2,85	3,55	2,27	3,12	3,88	2,62	3,63	4,22	2,89	4,14	4,85
Water flow rate system side	l/h			174	254	319	190	274	350	299	385	475	325	425	531	373	495	617	394	543	675	455	631	734	502	720	842
Pressure drop system side	kPa			6	12	18	8	15	22	8	12	18	9	14	21	10	16	24	6	11	16	12	21	28	10	20	26
Cooling performance 7 °C / 12 °C																											
Cooling capacity	kW			0,89	1,28	1,60	1,06	1,55	1,94	1,68	2,17	2,65	1,89	2,46	3,02	2,20	2,92	3,60	2,41	3,21	4,03	2,68	3,69	4,25	2,91	4,13	4,79
Sensible cooling capacity	kW			0,71	1,05	1,33	0,79	1,20	1,52	1,26	1,65	2,04	1,33	1,76	2,18	1,59	2,14	2,67	1,69	2,30	2,90	1,94	2,73	3,18	2,07	2,98	3,49
Water flow rate system side	l/h			153	221	275	182	267	334	288	374	456	350	460	560	379	503	619	414	552	694	460	634	731	501	711	824
Pressure drop system side	kPa			6	12	18	8	17	25	8	13	18	11	18	25	10	17	24	9	15	22	13	23	29	12	22	28
Fan																											
Type	type			Centrifugal																							
Fan motor	type			Inverter																							
Number	no.			1	1	2	2	2	2	2	2	2	2	2	2	2	2	2	2	2	2	2	2	2	2		
Air flow rate	m ³ /h			140	220	290	140	220	290	260	350	450	260	350	450	330	460	600	330	460	600	400	600	720	400	600	720
Input power	W			5	8	14	5	8	14	5	7	13	5	7	13	5	10	18	5	10	18	7	18	34	7	18	38
Signal 0-10V	%			44	68	90	44	68	90	52	70	90	52	70	90	49	68	90	49	68	90	50	74	90	50	74	90
Fan coil sound data (3)																											
Sound power level	dB(A)			35,0	46,0	51,0	35,0	46,0	51,0	34,0	41,0	48,0	34,0	41,0	48,0	37,0	44,0	51,0	37,0	44,0	51,0	42,0	51,0	56,0	42,0	51,0	56,0
Sound pressure	dB(A)			27,0	38,0	43,0	27,0	38,0	43,0	26,0	33,0	40,0	26,0	33,0	40,0	29,0	36,0	43,0	29,0	36,0	43,0	34,0	43,0	48,0	34,0	43,0	48,0
Diametre hydraulic fittings																											
Main heat exchanger	Ø			1/2"	1/2"	3/4"	3/4"	3/4"	3/4"	3/4"	3/4"	3/4"	3/4"	3/4"	3/4"	3/4"	3/4"	3/4"	3/4"	3/4"	3/4"	3/4"	3/4"	3/4"	3/4"		
Power supply																											
Power supply	230V~50Hz																										
	FCZI700			FCZI750			FCZI900			FCZI950																	
	1	2	3	1	2	3	1	2	3	1	2	3															
	L	M	H	L	M	H	L	M	H	L	M	H															
Heating performance 70 °C / 60 °C (1)																											
Heating capacity	kW			8,10	9,80	11,00	9,10	11,30	12,50	10,77	13,35	15,14	11,20	14,42	17,10												
Water flow rate system side	l/h			710	860	964	798	991	1096	945	1171	1328	982	1264	1500												
Pressure drop system side	kPa			17	23	29	10	15	18	12	17	22	16	25	33												
Heating performance 45 °C / 40 °C (2)																											
Heating capacity	kW			4,03	4,87	5,47	4,50	5,60	6,20	5,35	6,64	7,53	5,57	7,17	8,50												
Water flow rate system side	l/h			699	846	950	786	975	1079	930	1152	1307	967	1245	1476												
Pressure drop system side	kPa			17	24	29	10	15	18	12	17	22	15	24	33												
Cooling performance 7 °C / 12 °C																											
Cooling capacity	kW			3,92	4,89	5,50	4,27	5,34	6,14	4,29	5,00	6,91	5,77	7,32	8,60												
Sensible cooling capacity	kW			2,99	3,76	4,30	3,20	4,05	4,72	2,97	3,78	5,68	3,80	4,87	5,78												
Water flow rate system side	l/h			675	841	946	734	918	1056	738	860	1189	992	1259	1479												
Pressure drop system side	kPa			17	25	30	10	15	19	10	13	22	15	23	30												
Fan																											
Type	type			Centrifugal																							
Fan motor	type			Inverter																							
Number	no.			3	3	3	3	3	3	3	3	3	3	3													
Air flow rate	m ³ /h			700	930	1140	700	930	1140	700	930	1140	700	930	1140												
Input power	W			30	40	80	30	40	80	30	40	80	30	40	80												
Signal 0-10V	%			56	72	90	56	72	90	56	72	90	56	72	90												
Fan coil sound data (3)																											
Sound power level	dB(A)			50,0	57,0	62,0	50,0	57,0	62,0	51,0	57,0	62,0	51,0	57,0	62,0												
Sound pressure	dB(A)			42,0	49,0	54,0	42,0	49,0	54,0	43,0	49,0	54,0	43,0	49,0	54,0												
Diametre hydraulic fittings																											
Main heat exchanger	Ø			3/4"																							
Power supply																											
Power supply	230V~50Hz																										

(1) Room air temperature 20 °C d.b.; Water (in/out) 70 °C/60 °C

(2) Room air temperature 20 °C d.b.; Water (in/out) 45 °C/40 °C; EUROVENT

(3) Aermec determines the sound power value on the basis of measurements taken in accordance with standard UNI EN 16583:15, respecting the Eurovent certification.

Technical data - 4-pipe systems (main coil + secondary coil)

4-pipe

	FCZI201			FCZI301			FCZI401			FCZI501			FCZI701			FCZI901					
	1	2	3	1	2	3	1	2	3	1	2	3	1	2	3	1	2	3			
	L	M	H	L	M	H	L	M	H	L	M	H	L	M	H	L	M	H			
Heating performance 65 °C / 55 °C (1)																					
Heating capacity	kW			1,02	1,35	1,60	1,80	2,18	2,56	2,21	2,65	3,12	2,59	3,34	3,73	3,66	4,29	4,94	4,73	5,63	5,72
Water flow rate system side	l/h			89	118	140	158	191	224	186	232	273	227	293	327	320	375	437	414	492	501
Pressure drop system side	kPa			5	8	11	17	23	31	5	7	9	6	9	11	11	15	19	9	12	12
Cooling performance 7 °C / 12 °C																					
Cooling capacity	kW			0,89	1,28	1,60	1,68	2,17	2,65	2,20	2,92	3,60	2,68	3,69	4,25	3,92	4,89	5,50	4,29	5,00	6,91
Sensible cooling capacity	kW			0,71	1,05	1,33	1,26	1,65	2,04	1,59	2,14	2,67	1,94	2,73	3,18	2,99	3,76	4,30	2,97	3,78	5,68
Water flow rate system side	l/h			153	221	275	289	374	456	379	503	619	461	635	731	675	841	946	738	860	1188
Pressure drop system side	kPa			7	13	18	8	13	18	14	24	34	13	23	29	17	25	30	10	12	22
Fan																					
Type	type			Centrifugal																	
Fan motor	type			Inverter																	
Number	no.			1			2			2			2			3			3		
Air flow rate	m ³ /h			140	220	290	260	350	450	330	460	600	400	600	720	700	930	1140	700	930	1140
Sound pressure level (10 m)	dB(A)			27,0	38,0	43,0	26,0	33,0	40,0	29,0	36,0	43,0	34,0	43,0	48,0	42,0	49,0	54,0	43,0	49,0	54,0
Sound power level (2)	dB(A)			35,0	46,0	51,0	34,0	41,0	48,0	37,0	44,0	51,0	42,0	51,0	56,0	50,0	57,0	62,0	51,0	57,0	62,0
Diameter hydraulic fittings																					
Type	type			-																	
Main heat exchanger	Ø			1/2"			3/4"			3/4"			3/4"			3/4"			3/4"		
Fan																					
Input power	W			7	8	14	5	7	13	5	10	18	7	16	31	30	40	80	30	40	80
Signal 0-10V	%			44	68	90	52	70	90	49	68	90	50	74	90	56	72	90	56	72	90
Power supply																					
Power supply	230V~50Hz																				

(1) Room air temperature 20°C d.b.; Water (in/out) 65 °C/55 °C; EUROVENT

(2) Aermec determines the sound power value on the basis of measurements taken in accordance with standard UNI EN 16583:15, respecting the Eurovent certification.

DIMENSIONS

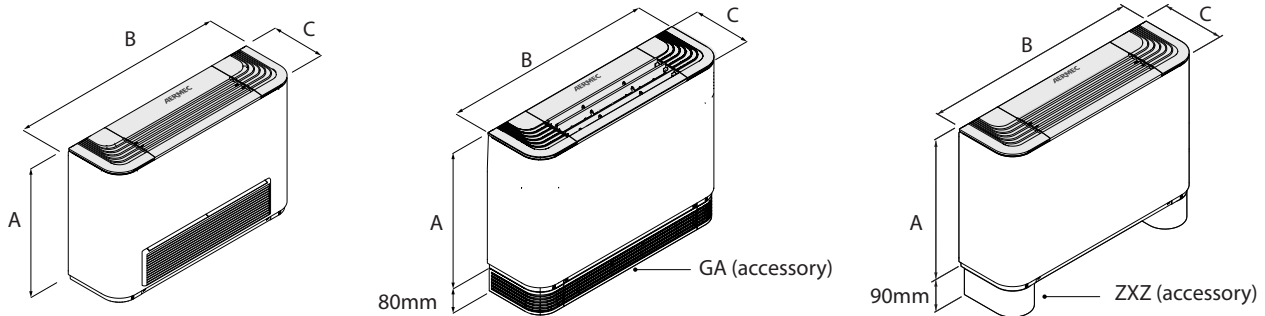

2-pipe

	FCZI200			FCZI250			FCZI300			FCZI350			FCZI400			FCZI450			FCZI500			FCZI550			FCZI700			FCZI750			FCZI900			FCZI950					
	1	2	3	1	2	3	1	2	3	1	2	3	1	2	3	1	2	3	1	2	3	1	2	3	1	2	3	1	2	3	1	2	3	1	2	3			
	L	M	H	L	M	H	L	M	H	L	M	H	L	M	H	L	M	H	L	M	H	L	M	H	L	M	H	L	M	H	L	M	H	L	M	H	L	M	H
A	mm			486	486	486	486	486	486	486	486	486	486	486	486	486	486	486	486	486	486	486	486	486	591	591	591	591	591	591	591	591	591						
B	mm			750	750	980	980	980	1200	1200	1200	1200	1200	1200	1200	1320	1320	1320	1320	1320	1320	1320	1320	1320	1320	1320	1320	1320	1320	1320	1320	1320	1320						
C	mm			220	220	220	220	220	220	220	220	220	220	220	220	220	220	220	220	220	220	220	220	220	220	220	220	220	220	220	220	220	220						
Empty weight	kg			15	16	17	17	18	22	22	24	22	22	24	22	24	29	29	29	31	31	31	31	31	34	34	34	34	34	34	34	34	34						

4-pipe

	FCZI201			FCZI301			FCZI401			FCZI501			FCZI701			FCZI901		
	1	2	3	1	2	3	1	2	3	1	2	3	1	2	3	1	2	3
	L	M	H	L	M	H	L	M	H	L	M	H	L	M	H	L	M	H
A	mm			486	486	486	486	486	486	486	486	486	486	486	486	591	591	591
B	mm			750	980	980	1200	1200	1200	1200	1200	1200	1320	1320	1320	1320	1320	1320
C	mm			220	220	220	220	220	220	220	220	220	220	220	220	220	220	220
Empty weight	kg			15	17	17	23	23	23	23	23	23	30	30	30	34	34	34

Aermec reserves the right to make any modifications deemed necessary. All data is subject to change without notice. Aermec does not assume responsibility or liability for errors or omissions.

Aermec S.p.A.

Via Roma, 996 - 37040 Bevilacqua (VR) - Italia
Tel. 0442633111 - Telefax 044293577
www.aermec.com